



Greensmaster® 3250-D

Model No. 04383 - 260000001 and up.

Parts Catalog

Ordering Replacement Parts

To order replacement parts, please supply the part number, the quantity, and the description of each part desired.

Understanding Reference Numbers

Each identified part in an illustration has a reference number. The reference number for a part also appears in the parts list, along with other information about the part.

This catalog uses two special reference number formats, one to indicate parts in a service assembly and another to indicate the quantity of a given part in an illustration.

Service Assembly Reference Numbers

Parts in service assemblies have reference numbers in the form a:b. The a represents the reference number of the entire service assembly and the b represents a sequential number unique to each part within the service assembly.

For example, a wheel assembly might be identified by reference number 6, the tire by 6:1, the valve by 6:2, and the wheel by 6:3. When you order the assembly identified by reference number 6, you receive all parts identified by reference numbers 6:1, 6:2, and 6:3. However, you may also order any part individually. Reference numbers of this type appear in illustrations and in part lists.

Reference Numbers Indicating Quantity

In an illustration, if a reference number indicates more than one part, the reference number has the form nX y. The n represents the quantity of the part, the X is the multiplication symbol, and the y represents the reference number.

For example, in an illustration, the reference number 2X 37 means that two of the parts identified by reference number 37 are indicated.

Contents

Description	Page	Description	Page
Traction Control Assembly 3	Manifold Block Installation Assembly 26
Brake Pedal Assembly 4	Mow/Lift Manifold Assembly No. 107-2570 27
Front Wheel and Brake Assembly 5	Front Bulkhead and Reel Motor Assembly 29
Brake Assembly No. 104-7705 6	Reel Motor Assembly No. 100-6426 30
Hydraulic Drive Motor Assembly No. 110-4015 7	Rear Bulkhead and Reel Motor Assembly 31
Hydraulic Drive Motor Assembly No. 110-4016 8	Left Hand and Right Hand Lift Arm Assembly 32
Steering Arm Assembly 9	Hydraulic Cylinder Assembly No. 105-3821 33
Steering Control Valve Assembly No. 105-0424 10	Center Lift Arm Assembly 34
Rear Wheel Assembly 11	Hydraulic Cylinder Assembly No. 105-3820 36
Steering Cylinder Assembly No. 93-2122 12	Fuel System Assembly 37
Console Assembly 13	Hydraulic Tank and Filter Assembly 38
Functional Control Lever Assembly 14	Miscellaneous Part Assembly 39
Seat Assembly 15	Pull Frame Assembly 40
Battery and Electrical Component Assembly 17	Cylinder Assembly 41
Hydrostat and Gear Pump Drive Assembly 18	Crankshaft Assembly 42
Hydrostat Assembly No. 105-0494 19	Cylinder Head Assembly 43
Gear Pump Assembly No. 104-7737 20	Injection Assembly 44
Neutral System Assembly 21	Rocker Arm Assembly 45
Engine Installation Assembly 22	Oil Pan Assembly 46
Air Cleaner and Exhaust Assembly 23	Cover Assembly 47
Air Cleaner Assembly No. 95-5805 24	Gear Housing Assembly 48
Radiator Assembly 25	Water Pump Assembly 49
		Manifold Assembly 50
		Alternator Assembly 51
		Gasket and Valve Overhaul Kit 52
		Attachments and Accessories List 53

Part Description Abbreviations

Part descriptions in this catalog may include the following abbreviations.

AR. as required	INC. incorporated
ASM. assembly	LH. left hand
BBC. blade brake clutch	NI. nylon insert
CARR. carriage	NPTF. national pipe thread fine
DEG. degrees	PFH. phillips flat head
EXT. external	PPH. phillips pan head
FH. flat head	PPHTF. phillips pan head thread forming
GA. gauge	PRH. phillips round head
HF. hex flange	PTH. phillips truss head
HH. hex head	PTO. power-take-off
HHF. hex head flange	RH. right hand
HHFTF. hex head flange thread forming	ROPS. roll-over-protection-system
HJ. hex jam	SFH. slotted fillister head
HLH. hex lag head	SHH. slotted hex head
HOC. height-of-cut	SHWH. slotted hex washer head
HSBH. hex socket button head	SPH. slotted pan head
HSFH. hex socket flat head	SQH. square head
HSH. hex socket head	SRH. slotted round head
HWH. hex washer head	STD. standard
HWHTF. hex washer head thread forming	TAP. self tapping
HYD. hydraulic	TTH. torx truss head

Footnotes

- ❶ Not illustrated
- ❷ Not serviced separately
- ❸ Included in Gasket Set-Part Number 99-9667

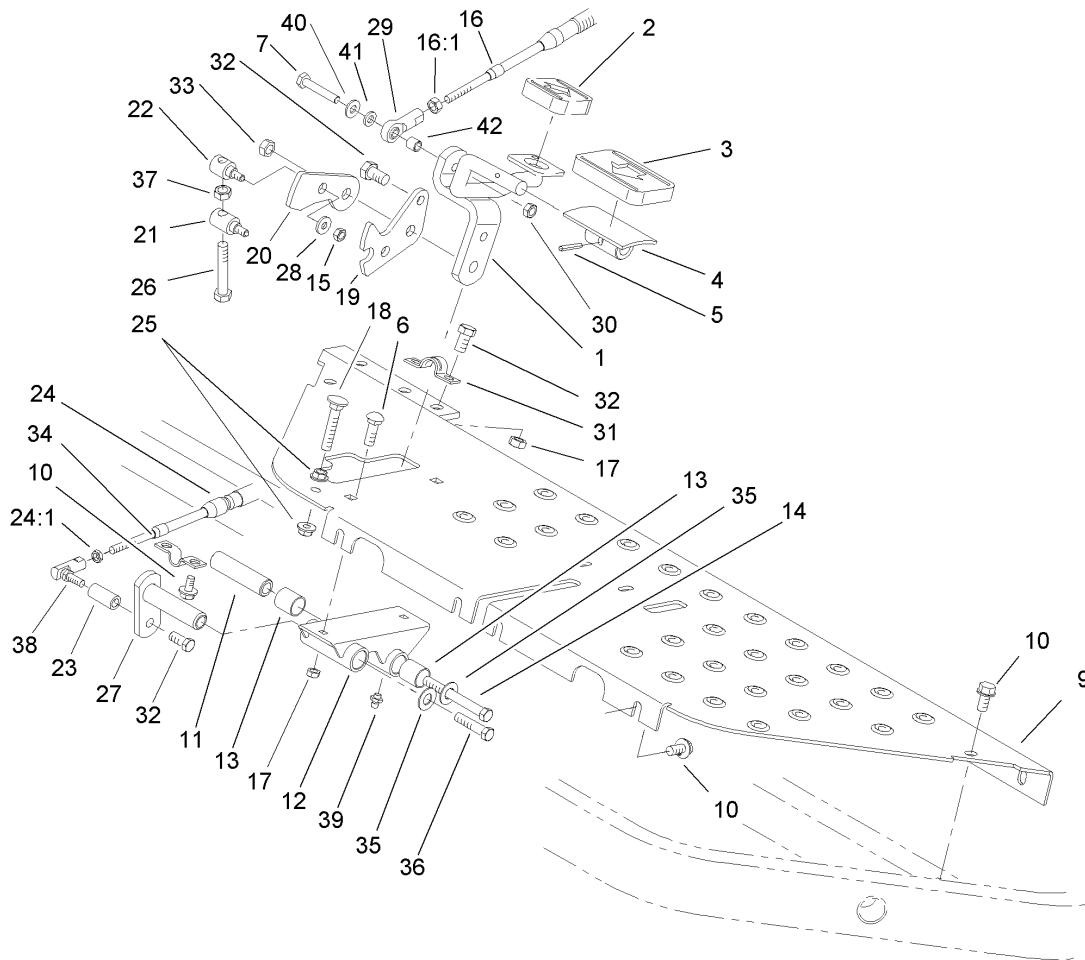

Traction Control Assembly

Ref	Part No.	Qty.	Description
1	93-2085-01	1	Rod ASM
2	74-9110	1	Pad-Pedal, Reverse
3	74-9100	1	Pad-Pedal, Forward
4	49-6440-03	1	Pedal-Forward
5	32121-45	1	Pin-Spring
6	33124-020	2	Screw-CARR
7	321-9	1	Screw-HH
9	105-9750-01	1	Plate-Floor
10	32104-32	8	Screw-HH
11	94-1371	1	Spacer
12	94-1383	1	Pedal-Pivot
13	256-311	4	Bushing-Split
14	33115-090	1	Screw-HH
15	33023-00	2	Nut-Lock
16	107-2550	1	Cable-Control, Traction
16:1	3220-1	2	Nut-Jam
17	33024-00	4	Nut-Lock
18	17-9420	1	Screw-Handle
19	94-1373	1	Bracket-Lock
20	94-1372	1	Bracket-Mow
21	94-1375	1	Trunnion-Bracket, Lock
22	94-1374	1	Trunnion-Bracket, Mow
23	94-1386	1	Shaft-Pedal, Pivot
24	94-1304	1	Cable-Lock, Neutral

Ref	Part No.	Qty.	Description
24:1	3219-14	2	Nut-Hex
25	32128-20	2	Nut-HF
26	94-3489	1	Capscrew-HH
27	94-1300	1	Lock-Neutral
28	3256-1	2	Washer-Flat
29	2411-41	1	Joint-Ball
30	3296-56	1	Nut-Lock, NI
31	93-2092	1	Clamp-Cable
32	33114-016	4	Screw-HH
33	33025-00	1	Nut-Lock
34	93-2279	1	Clamp-Cable
35	3256-24	2	Washer-Flat
36	33115-016	1	Screw-HH
37	33014-00	1	Nut-Hex
38	2411-38	1	Joint-Ball
39	302-5	1	Fitting-Grease
40	3256-22	1	Washer-Flat
41	33093-00	1	Washer-Flat
42	99-3545	1	Spacer

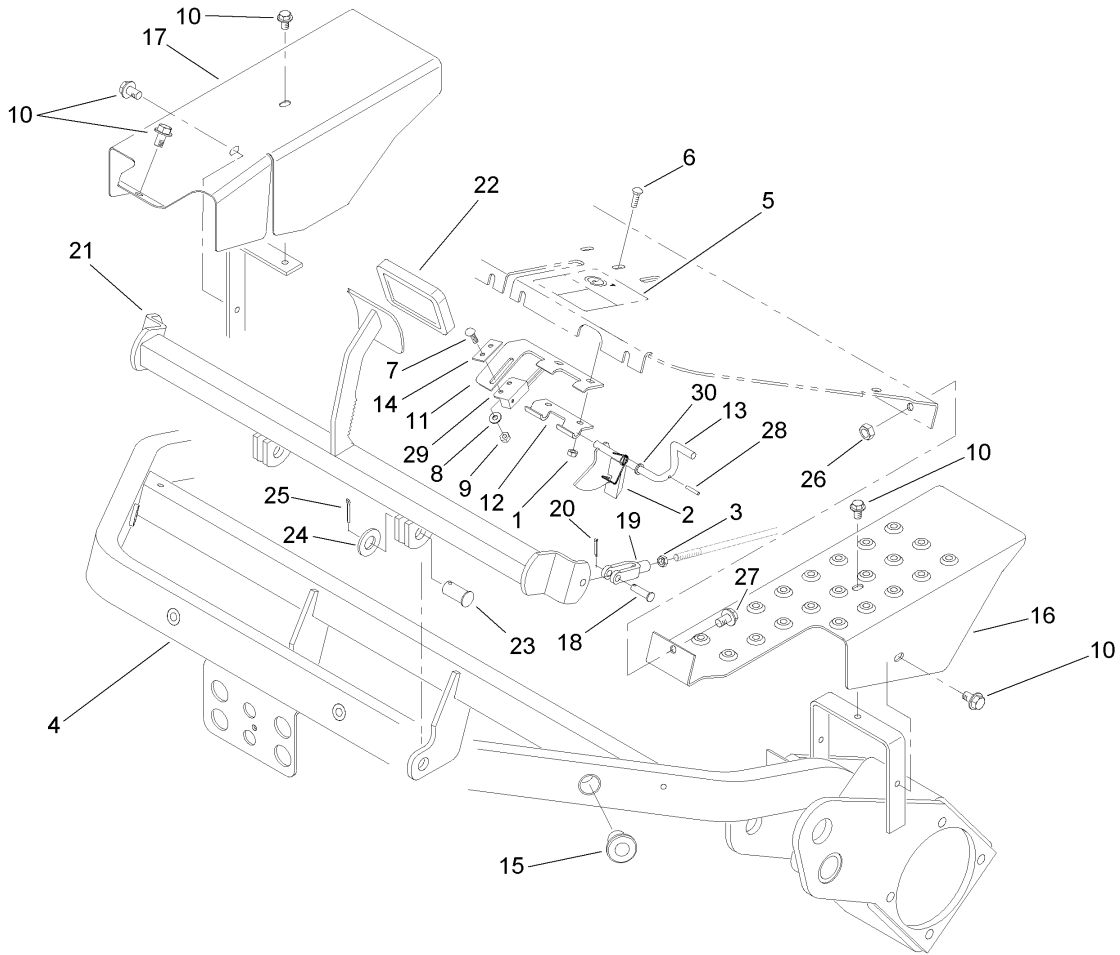

Brake Pedal Assembly

Ref	Part No.	Qty.	Description
1	33023-00	2	Nut-Lock
2	104-7704	1	Spring-Latch, Brake
3	3220-2	2	Nut-Jam
4	107-9543-01	1	Frame ASM
5	93-8062	1	Decal-Brake, Parking
6	33123-016	2	Screw-CARR
7	33123-016	1	Screw-CARR
8	33093-00	1	Washer-Flat
9	49-7810	1	Nut-Lock
10	32104-32	5	Screw-HH
11	104-2096	1	Bracket-Switch
12	104-7703	1	Hinge-Lower
13	104-2094	1	Brake-Latch
14	104-7702	1	Plate-Switch
15	83-1700	3	Bushing-Flange
16	93-2073-01	1	Shield-Wheel, LH
17	93-2072-01	1	Shield-Wheel, RH
18	283-61	2	Pin-Yoke
19	282-2	2	Yoke
20	3272-6	2	Pin-Cotter
21	93-2075-01	1	Pedal-Brake ASM
22	93-7629	1	Pad-Foot, Brake
23	283-87	2	Pin-Clevis
24	3256-27	2	Washer-Flat

Ref	Part No.	Qty.	Description
25	3272-11	2	Pin-Cotter
26	33024-00	1	Nut-Lock
27	33114-020	1	Screw-HH
28	32121-50	1	Pin-Spring
29	104-2057	1	Sensor
30	75-5470	1	Spacer-Bearing

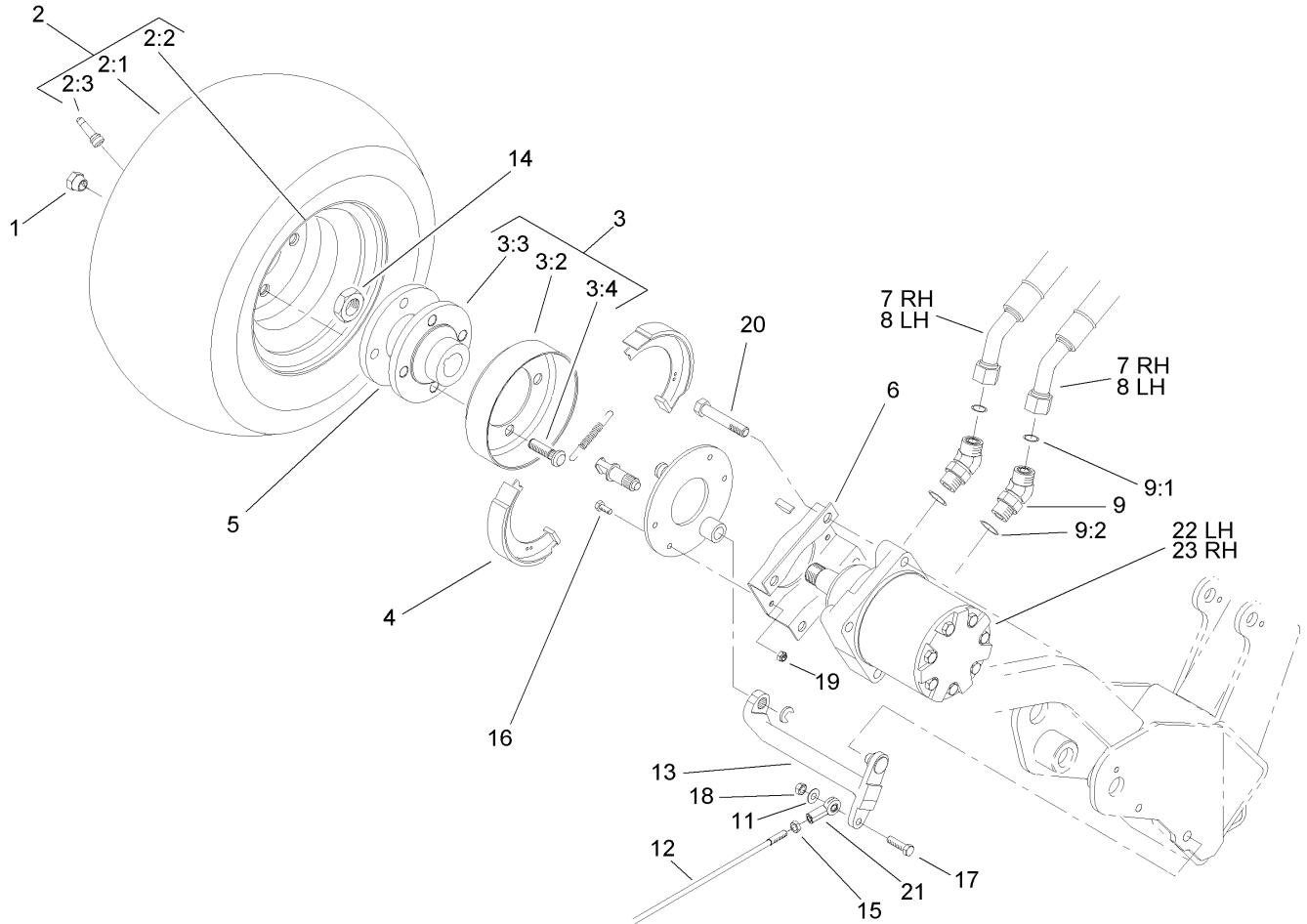

Front Wheel and Brake Assembly

Ref	Part No.	Qty.	Description
1	242-50	8	Nut-Lug
2		2	Wheel And Tire ASM
2:1	70-8500	1	Tire
2:2	94-6116	1	Wheel-Rear
2:3	232-27	1	Stem-Valve
3	10-6821	2	Brake Drum ASM
3:2	10-6850	1	Drum-Brake
3:3	10-6870-03	1	Hub-Wheel
3:4	85-6540	4	Stud-Drive
4	104-7705	2	Brake ASM
5	92-9154-03	2	Plate-Bearing
6	84-2000-03	2	Bracket-Brake
7	94-5357	2	Hose ASM
8	94-5358	2	Hose ASM
9	340-14	4	Fitting-HYD, 45 DEG
9:1	237-65	1	O-Ring
9:2	237-80	1	O-Ring
11	3256-23	2	Washer-Flat
12	93-2069	2	Rod-Brake
13	93-2096	2	Lever-Brake
14	26-3790	2	Nut-Lock
15	3220-20	2	Nut-Jam
16	33113-020	8	Screw-HH
17	33114-030	2	Screw-HH

Ref	Part No.	Qty.	Description
18	33024-00	2	Nut-Lock
19	33023-00	8	Nut-Lock
20	33116-060	8	Screw-HH
21	93-2070	2	Clevis-Swivel
22	110-4015	1	Wheel Motor-LH
23	110-4016	1	Wheel Motor-RH

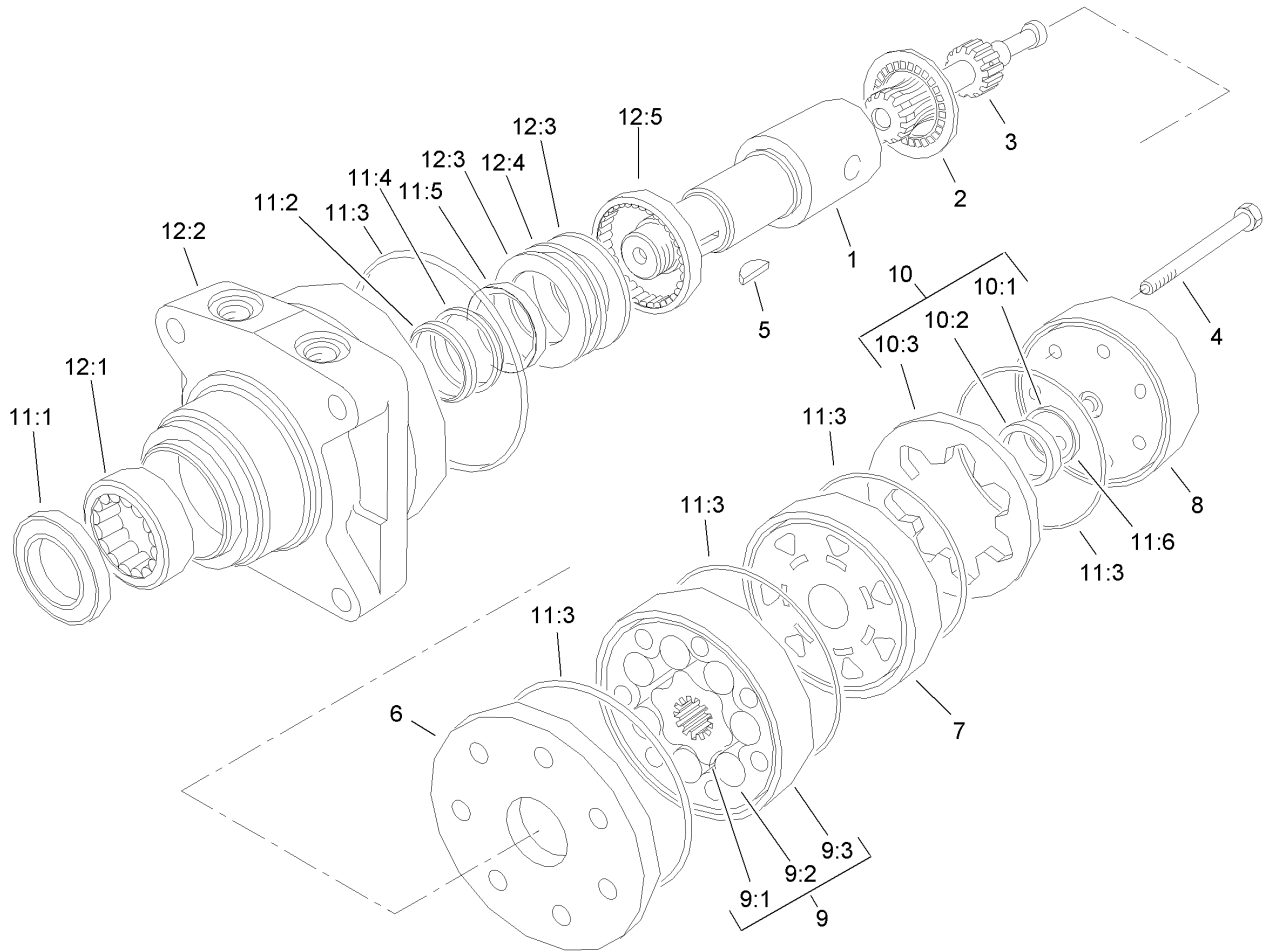

Hydraulic Drive Motor Assembly No. 110-4015

Ref	Part No.	Qty.	Description
1	76-0860	1	Shaft-Coupling
2	76-0850	1	Bearing-Thrust
3	92-9761	1	Link-Drive
4	92-9762	7	Screw-HH
5	3257-42	1	Key-Woodruff
6	76-0870	1	Plate-Wear
7	76-0840	1	Manifold
8	76-0940	1	End Cover ASM
9	92-9763	1	Rotor Set
●9:1		1	Rotor
●9:2		1	Vane
●9:3		1	Stator
10	76-0880	1	Commutator ASM
●10:1		1	Seal-Commutator
●10:2		1	Commutator
●10:3		1	Ring-Commutator
11	94-8178	1	Seal Kit
●11:1		1	Seal-Dirt And Water
●11:2		1	Washer-Backup
●11:3		5	Seal-Ring
●11:4		1	Washer-Backup
●11:5		1	Seal-Inner
●11:6		1	Seal-Commutator
12	76-0810	1	Housing ASM

Ref	Part No.	Qty.	Description
●12:1		1	Bearing
●12:2		1	Housing
●12:3		2	Washer-Thrust
●12:4		1	Bearing-Thrust
●12:5		1	Bearing

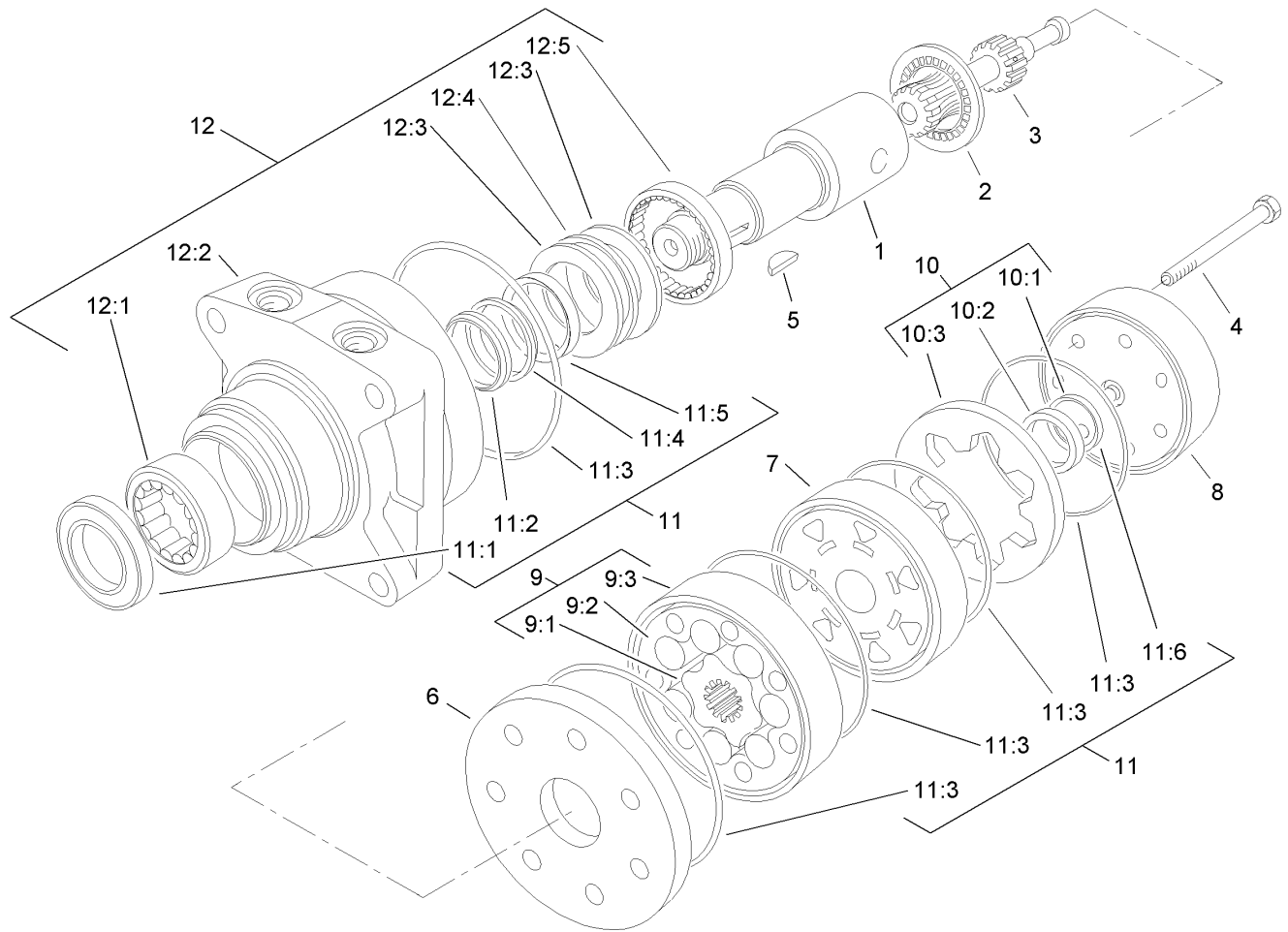

Hydraulic Drive Motor Assembly No. 110-4016

Ref	Part No.	Qty.	Description
1	76-0860	1	Shaft-Coupling
2	76-0850	1	Bearing-Thrust
3	92-9761	1	Link-Drive
4	92-9762	7	Screw-HH
5	3257-42	1	Key-Woodruff
6	76-0870	1	Plate-Wear
7	76-0840	1	Manifold
8	76-0940	1	End Cover ASM
9	92-9763	1	Rotor Set
●9:1		1	Rotor
●9:2		1	Vane
●9:3		1	Stator
10	76-0880	1	Commutator ASM
●10:1		1	Seal-Commutator
●10:2		1	Commutator
●10:3		1	Ring-Commutator
11	94-8178	1	Seal Kit
●11:1		1	Seal-Dirt And Water
●11:2		1	Washer-Backup
●11:3		5	Seal-Ring
●11:4		1	Washer-Backup
●11:5		1	Seal-Inner
●11:6		1	Seal-Commutator
12	76-0810	1	Housing ASM

Ref	Part No.	Qty.	Description
●12:1		1	Bearing
●12:2		1	Housing
●12:3		2	Washer-Thrust
●12:4		1	Bearing-Thrust
●12:5		1	Bearing

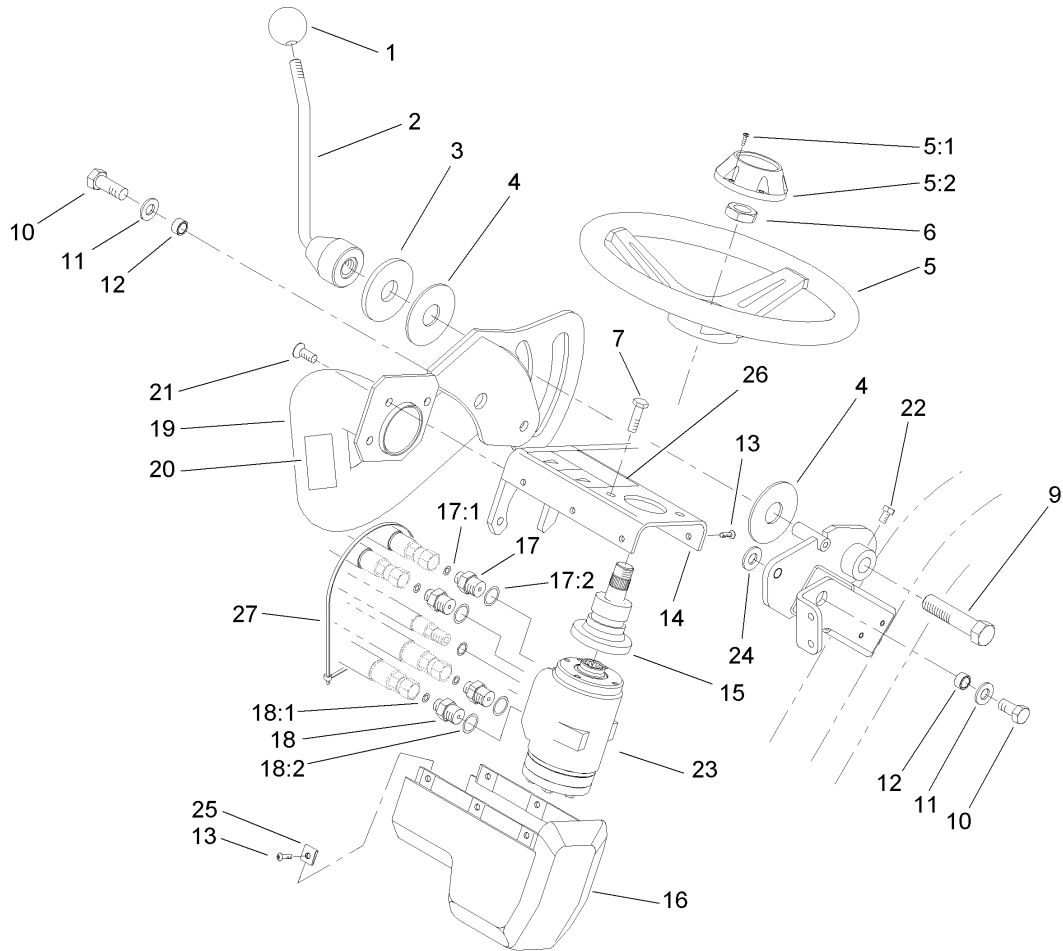

Steering Arm Assembly

Ref	Part No.	Qty.	Description	Ref	Part No.	Qty.	Description
1	233-48	1	Knob	20	93-8068	1	Decal-Arm, Steering
2	93-2400-03	1	Lockup Handle ASM	21	3274-80	3	Screw-HH
3	83-0760	1	Spacer-Plate, Lockup	22	3242-2	1	Screw-SQH
4	83-0740	2	Disc-Friction	23	105-0424	1	Valve-Control, Steering
5	75-0560	1	Wheel-Steering	24	65-6390	1	Washer-Thrust, Plain
5:1	32144-21	1	Screw	25	3290-277	6	Nut-Speed
5:2	68-5140	1	Cap-Wheel, Steering	26	104-2053	1	Decal-Warning
6	107-2562	1	Nut-Hex	26	93-8063	1	Decal-Caution, Ce
7	33103-016	4	Screw-HHF	27	3290-379	1	Tie-Cable
9	93-2199	1	Screw-HH, RH				
10	325-4	2	Screw-HH				
11	3256-26	2	Washer-Flat				
12	47-2890	2	Bushing				
13	3274-39	6	Screw-HSBH				
14	105-9791-03	1	Steering Cover ASM				
15	105-0425	1	Steering Column ASM				
16	83-0810	1	Cover-Steering				
17	340-1	2	Adapter				
17:1	237-21	1	O-Ring				
17:2	237-42	1	O-Ring				
18	340-2	2	Fitting-HYD, Straight				
18:1	237-22	1	O-Ring				
18:2	237-42	1	O-Ring				
19	93-2115-01	1	Steering Arm ASM				

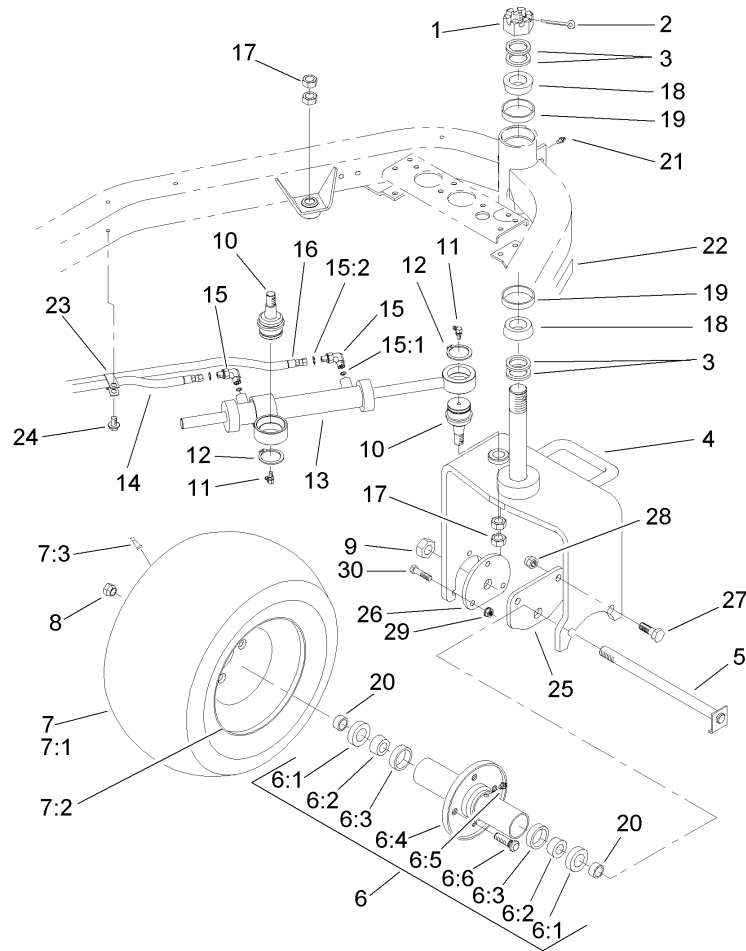

Rear Wheel Assembly

Ref	Part No.	Qty.	Description	Ref	Part No.	Qty.	Description
1	32136-9	1	Nut-Hex, Slotted	15:1	237-78	1	O-Ring
2	3272-37	1	Pin-Cotter	15:2	237-21	1	O-Ring
3	18-6320	4	Washer-Steering	16	93-2269	1	HYD Hose ASM
4	99-1492-01	1	Castor Fork ASM	17	3220-6	4	Nut-Jam
5	70-8370	1	Bolt	18	254-70	2	Bearing-Cone
6	72-9710	1	Hub-Tire	19	254-61	2	Cup-Bearing
6:1	253-111	2	Seal-Oil	20	70-8490	2	Spacer-Spindle, Rear
6:2	254-78	2	Bearing-Cone	21	302-5	1	Fitting-Grease
6:3	254-79	2	Bearing-Roller, Cup	22	99-1493	1	Decal
6:4	75-9440	1	Hub ASM	23	92-5753	1	Clamp-Hose
6:5	302-11	1	Fitting-Lube, 45 DEG	24	32104-32	1	Screw-HH
6:6	10-6830	4	Stud-Type, Drive	25	99-1485-01	1	Plate-Adapter, Motor
7		1	Wheel And Tire ASM	26	99-1486-01	1	Plate-Adapter
7:1	70-8500	1	Tire	27	325-6	2	Screw-HH
7:2	94-6116	1	Wheel-Rear	28	3296-23	2	Nut-Lock, NI
7:3	232-27	1	Stem-Valve	29	3296-39	3	Nut-Lock, NI
8	242-50	4	Nut-Lug	30	323-8	3	Screw-HH
9	3296-67	1	Nut-Lock NI				
10	106-6774	2	Joint-Ball				
11	302-60	2	Fitting-Grease, 90 DEG				
12	32151-104	2	Ring-Retaining, External				
13	93-2122	1	Steering Cylinder ASM				
14	93-2270	1	HYD Hose ASM				
15	340-132	2	Fitting-HYD, 90 DEG				

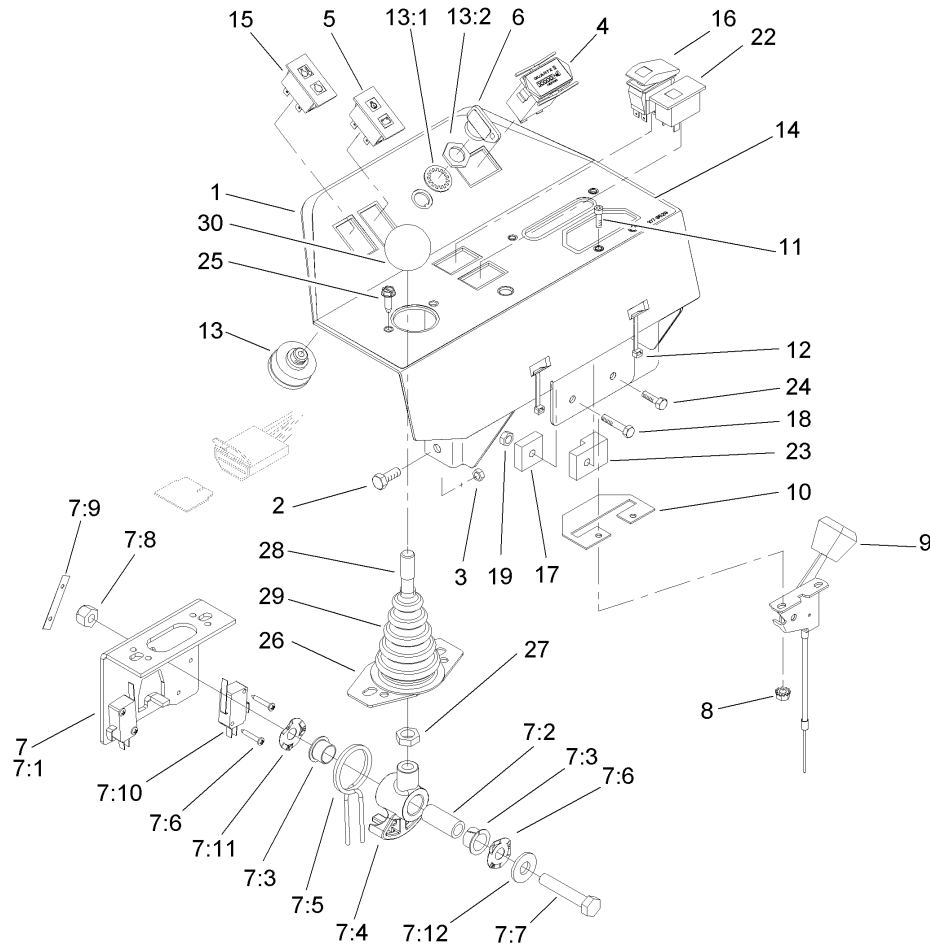

Console Assembly

Ref	Part No.	Qty.	Description	Ref	Part No.	Qty.	Description
1	108-6503-03	1	Console ASM	13	27-2360	1	Switch-Key
2	33114-020	4	Screw-HH	13:1	218-446	1	Nut-Hex
3	33024-00	4	Nut-Lock	13:2	218-447	1	Washer-Lock
4	1-513374	1	Meter-Hour	14	107-9529	1	Decal-Instrument
5	100-8070	1	Lamp-Warning	15	100-8071	1	Lamp-Warning
6	63-8360	1	Key-Ignition	16	100-8072	1	Switch
7	106-4167	1	Joystick Bracket ASM	17	92-2538	1	Module-Timer
7:1	106-4168-03	1	Bracket-Joystick	18	33113-030	1	Screw-HH
7:2	106-4192	1	Spacer	19	33023-00	2	Nut-Lock
7:3	93-5547	2	Bushing-Nylon	22	108-6531	1	Indicator-Light, Amber
7:4	105-7507	1	Hub-Pivot, Joystick	23	99-9666	1	Module
7:5	105-8289	1	Spring-Torsion	24	33113-020	1	Screw-HH
7:6	106-4193	2	Washer-Finger, Spring	25	32144-19	2	Screw-SHWH
7:7	322-9	1	Screw-HH	26	106-4188-03	1	Plate-Boot
7:8	3296-29	1	Nut-Lock, NI	27	3218-3	1	Nut-Jam
7:9	3290-354	2	Nut-Speed	28	105-8288	1	Rod-Joystick
7:10	108-6496	2	Switch W/Boot	29	93-5961	1	Boot-Lever
7:11	95-3003	4	Screw-HH	30	233-42	1	Knob
7:12	3256-3	1	Washer-Flat				
8	32149-8	2	Nut-Keps				
9	99-8150	1	Control-Throttle				
10	99-8195-03	1	Plate-Cover				
11	3273-26	2	Screw-HSH				
12	3290-378	2	Tie-Cable				

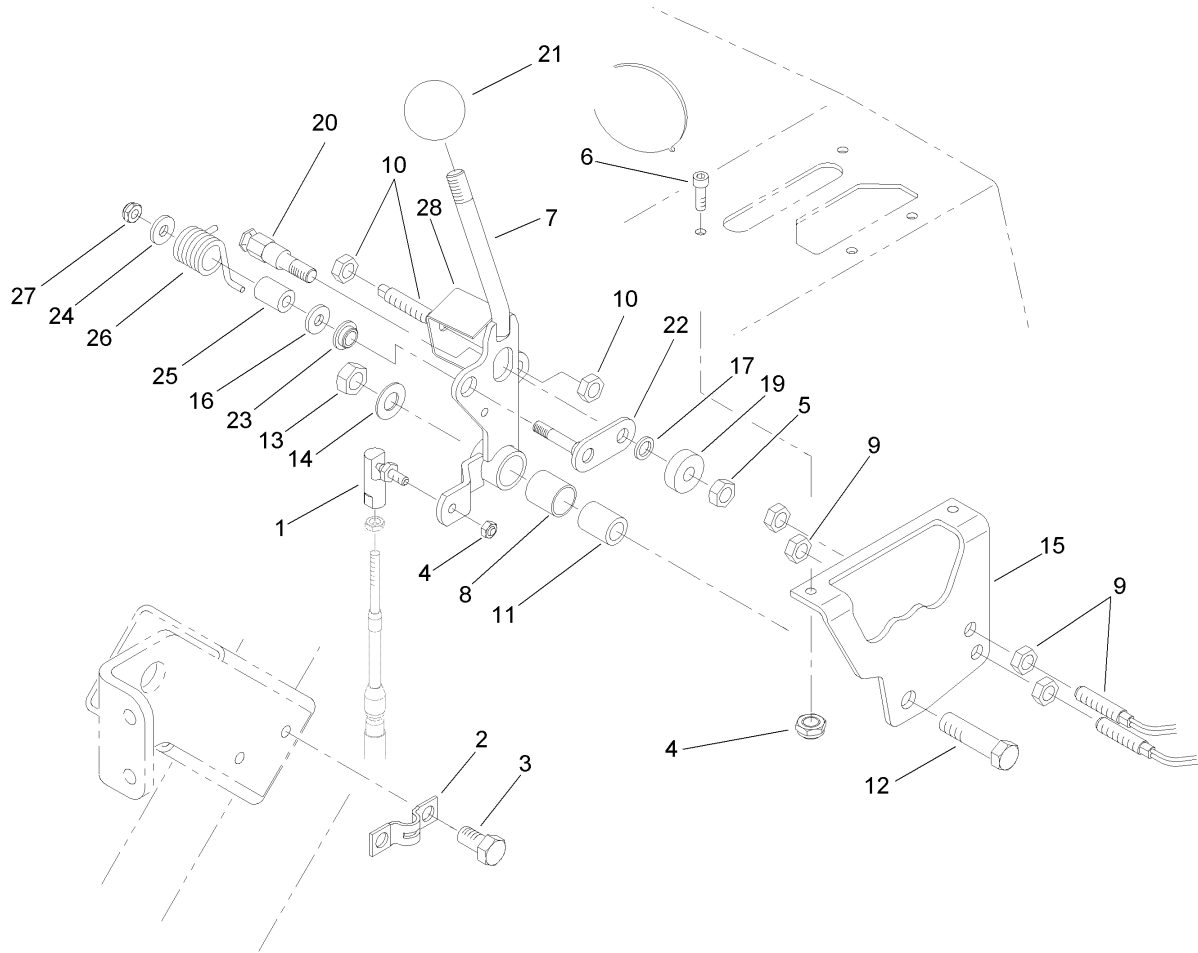

Functional Control Lever Assembly

Ref	Part No.	Qty.	Description
1	2411-38	1	Joint-Ball
2	93-2279	1	Clamp-Cable
3	32104-32	2	Screw-HH
4	3296-27	2	Nut-Lock NI
5	33024-00	1	Nut-Lock
6	3273-26	2	Screw-HSH
7	94-9611	1	Handle
8	256-311	1	Bushing-Split
9	93-2055	2	Sensor-Switch, Reed
10	93-2056	1	Actuator-Switch, Reed
11	94-1378	1	Tube-Pivot, Handle
12	33115-040	1	Screw-HH
13	33025-00	1	Nut-Lock
14	3256-24	1	Washer-Flat
15	94-6398	1	Bracket-Traction
16	3256-23	1	Washer-Flat
17	75-5470	1	Spacer-Bearing
19	251-259	1	Bearing-Ball
20	94-9617	1	Pin-Spring
21	233-42	1	Knob
22	94-9614	1	Pivot-Roller
23	94-9619	1	Bushing
24	3256-67	1	Washer-Flat
25	94-9618	1	Spacer-Spring

Ref	Part No.	Qty.	Description
26	94-9620	1	Spring-Torsion
27	33023-00	1	Nut-Lock
28	106-6356	1	Shield-Switch

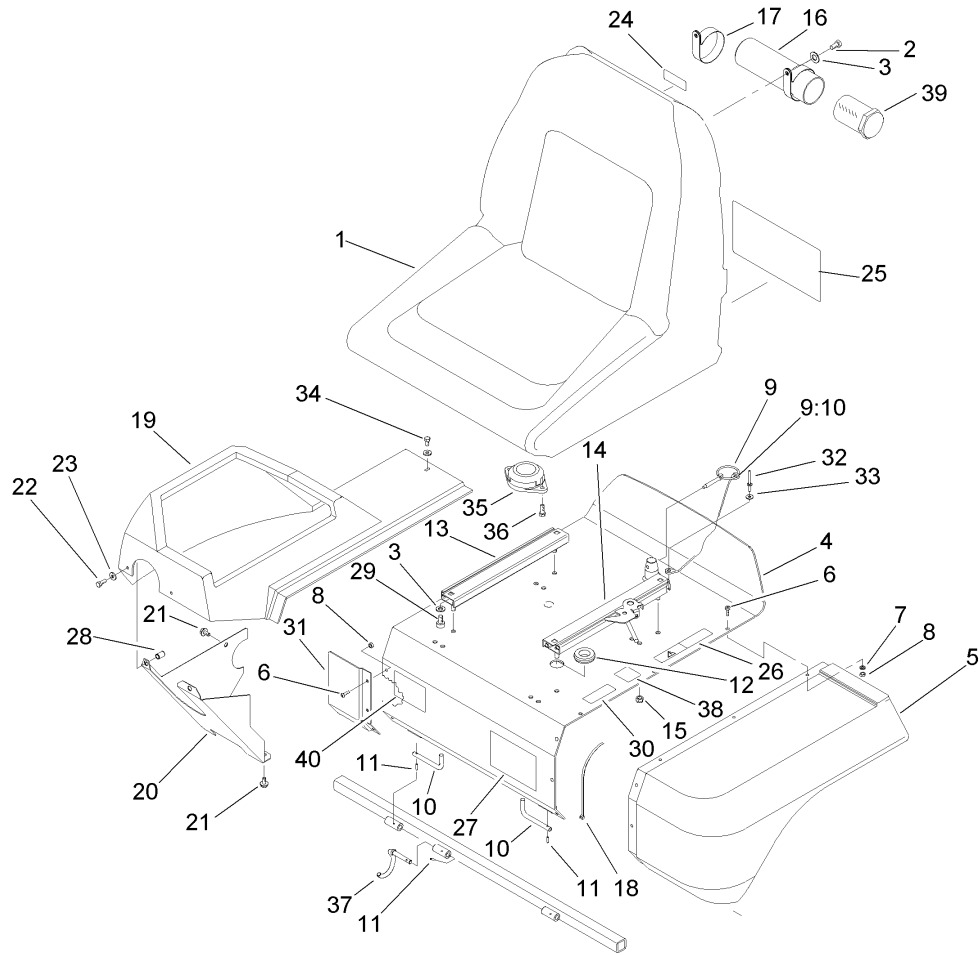

Seat Assembly

Ref	Part No.	Qty.	Description
1	104-4620	1	Seat
2	322-2	2	Screw-HH
3	3256-23	6	Washer-Flat
4	93-2135-03	1	Support-Seat ASM
5	93-2128	1	Panel-Base, Seat
6	3274-39	9	Screw-HSBH
7	3256-77	6	Washer-Flat
8	3296-12	9	Nut-Lock
9	77-3780	1	Pin ASM
9:10	28-8070	1	Lanyard
10	93-2422	2	Rod-Pivot, Seat
11	32121-7	3	Pin-Roll, Slotted
12	237-100	1	Grommet
13	92-8990	1	Adjuster-7 Inch
14	92-8991	1	Adjuster W/Latch
15	3296-29	4	Nut-Lock, NI
16	104-7050	1	Housing-Manual
17	2412-133	2	R-Clamp
18	3290-378	1	Tie-Cable
19	99-4208	1	Shroud-Console
20	94-4547-03	1	Panel-Lower, RH
21	32104-32	2	Screw-HH
22	33113-016	2	Screw-HH
23	3256-1	3	Washer-Flat

Ref	Part No.	Qty.	Description
24	93-6686	1	Decal-Oil, HYD
25	106-6381	1	Decal-Service, French
25	106-6380	1	Decal-Service, Spanish
25	106-6379	1	Decal-Service
25	106-6382	1	Decal-Service, German
25	106-6383	1	Decal-Service, Swedish
25	106-6384	1	Decal-Service, Italian
25	106-6388	1	Decal-Service, Danish
25	106-6387	1	Decal-Service, Finnish
25	106-6386	1	Decal-Service, Norwegian
25	106-6389	1	Decal-Service, Dutch
25	106-6390	1	Decal-Service, Japanese
25	106-6385	1	Decal-Service, Portuguese
26	93-6689	1	Decal-No Riders
27	94-2579	1	Decal
28	93-5447	2	Nut-Clinch
29	3274-12	4	Screw-HSH
30	93-7252	1	Decal
31	94-4546-03	1	Panel-Extension
32	3290-282	1	Rivet-Pop
33	3256-49	1	Washer-Flat
34	33113-012	1	Screw-HH
35	92-6282	1	Switch-Seat
36	32144-10	2	Screw-HWH

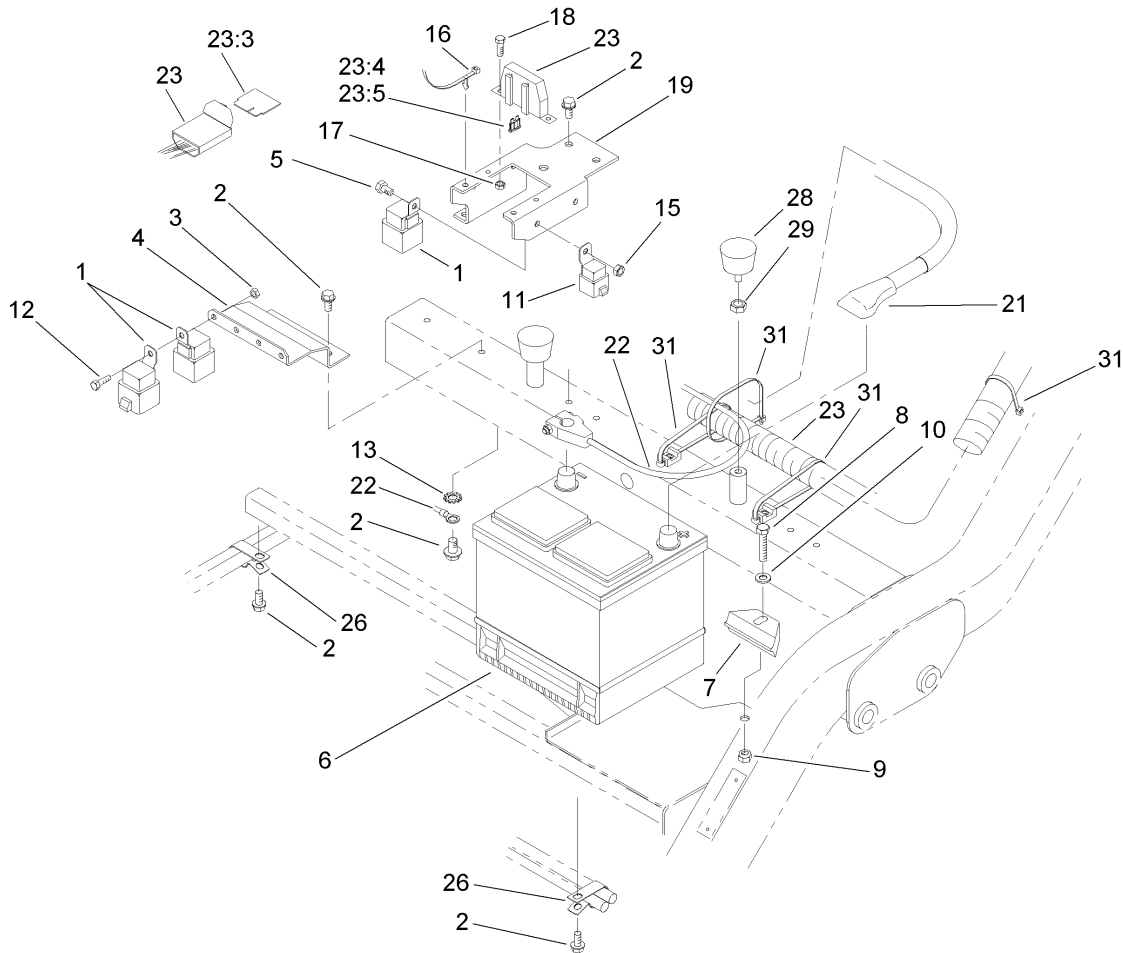

Battery and Electrical Component Assembly

Ref	Part No.	Qty.	Description
1	99-7430	9	Relay
2	32144-11	7	Screw-HWHTF
3	33023-00	4	Nut-Lock
4	93-2169-01	1	Bracket-Relay
5	3290-134	1	Screw
6	106-5187	1	Battery
7	66-2490	1	Retainer-Battery
8	33115-040	1	Screw-HH
9	33025-00	1	Nut-Lock
10	3256-24	1	Washer-Flat
11	99-7435	1	Relay-Power
12	33113-016	4	Screw-HH
13	3254-2	1	Washer-Lock, Internal
15	3296-2	1	Nut-Lock
16	94-1325	2	Tie-Mount, Push
17	3296-2	2	Nut-Lock
18	32105-13	2	Screw-SHH
19	100-3186-03	1	Bracket-Holder, Fuse
21	95-8853	1	Cable-Battery, Positive
22	99-8167	1	Cable-Battery, Negative
23	110-3984	1	Harness-Wire
23:3	92-3188	2	Diode-Board, Circuit
23:4	109355	1	Fuse-15 Amp
23:5	218-578	2	Fuse-10 Amp

Ref	Part No.	Qty.	Description
●23:6	104-4022	1	Resistor-75 Ohm
26	92-5753	2	Clamp-Hose
28	68-3270	2	Bumper-Rubber
29	3218-2	2	Nut-Jam
31	3290-378	6	Tie-Cable
●32	99-3441	1	Harness-Wire, Fusible Link

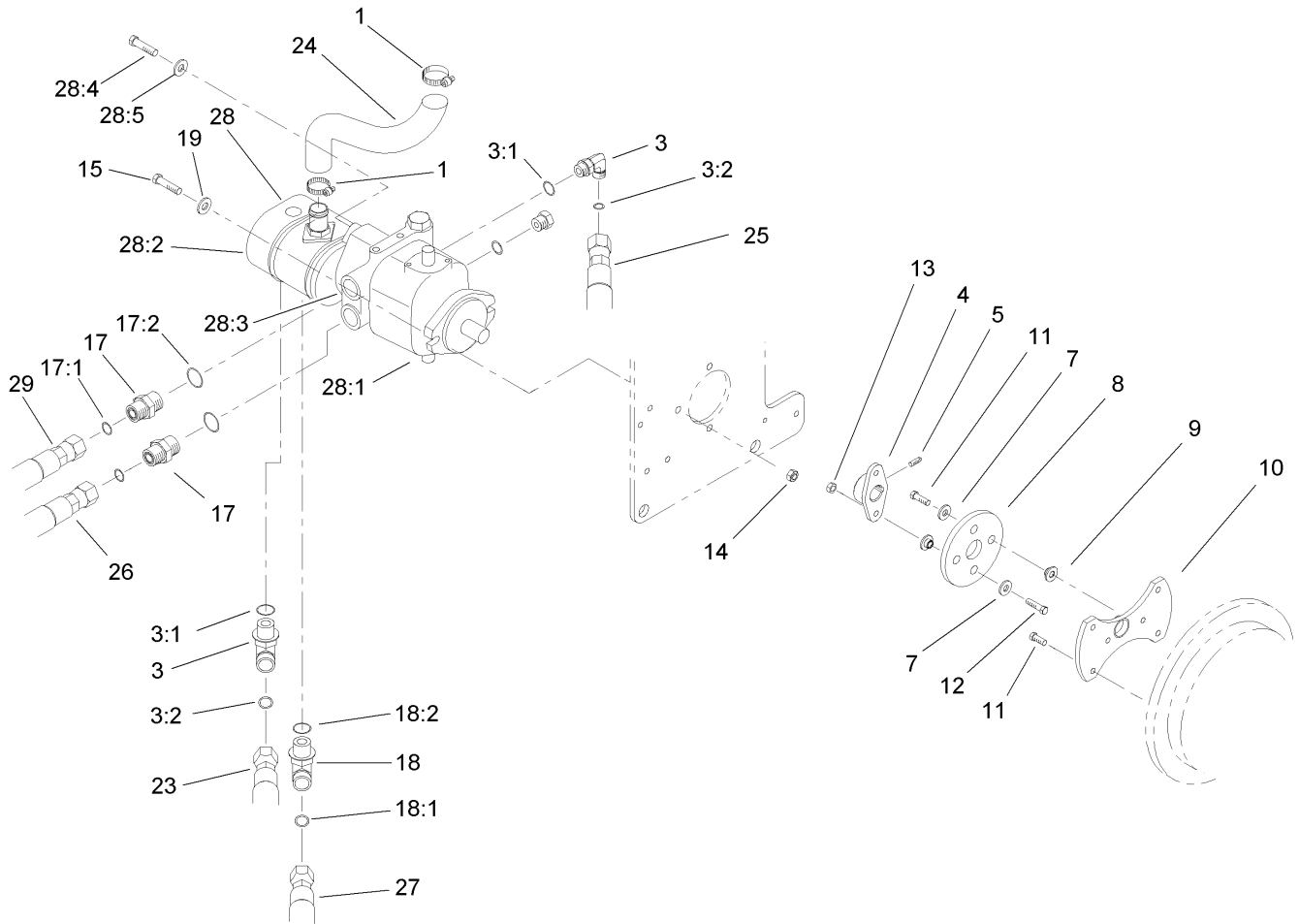

Hydrostat and Gear Pump Drive Assembly

Ref	Part No.	Qty.	Description
1	2412-34	2	Clamp-Hose
3	340-18	2	Fitting-HYD, 90 DEG
3:1	237-79	1	O-Ring
3:2	237-22	1	O-Ring
4	93-2589	1	Hub-Pump
5	3241-6	2	Screw-SQH
7	3256-3	2	Washer-Flat
8	80-8650	1	Coupling-Drive
9	27-6600	4	Spacer-Coupling
10	93-2220-03	1	Adapter-Pump ASM
11	33114-020	6	Screw-HH
12	33114-030	1	Screw-HH
13	33024-00	2	Nut-Lock
14	33025-00	2	Nut-Lock
15	33115-040	2	Screw-HH
17	340-8	2	Adapter
17:1	237-65	1	O-Ring
17:2	237-81	1	O-Ring
18	340-17	1	Fitting-HYD, 90 DEG
18:1	237-65	1	O-Ring
18:2	237-80	1	O-Ring
19	100-4852	2	Washer-Hardened
23	105-4339	1	HYD Hose ASM
24	99-1905	1	Hose-Inlet, Pump

Ref	Part No.	Qty.	Description
25	108-6514	1	Hose ASM
26	99-4220	1	Hose ASM
27	99-4216	1	Hose ASM
28		1	Hydrostat/Gear Pump ASM
28:1	105-0494	1	Hydrostat ASM
28:2	104-7737	1	Gear Pump ASM
28:3	60-3520	1	O-Ring
28:4	3274-1	2	Screw-HSH
28:5	3256-24	2	Washer-Flat
29	99-4217	1	Hose ASM

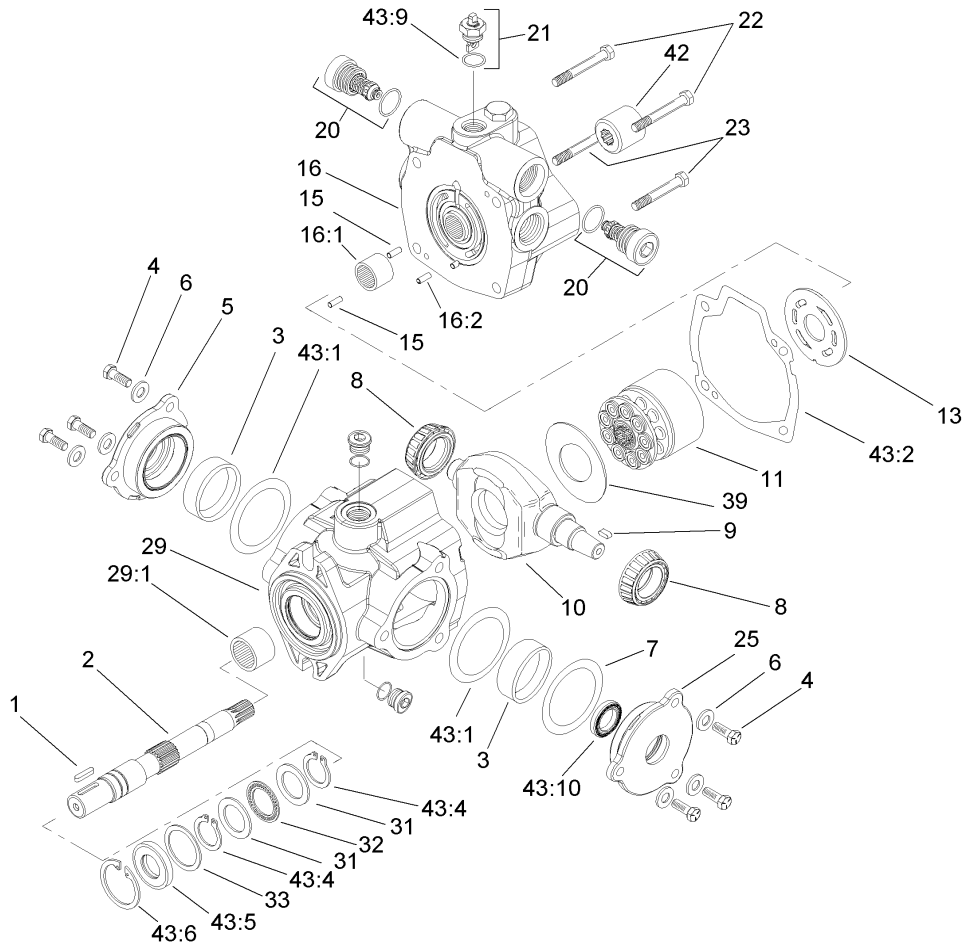

Hydrostat Assembly No. 105-0494

Ref	Part No.	Qty.	Description
1	94-3645	1	Key
2	94-6359	1	Shaft-Drive
3	104-4046	2	Bearing-Cup
4	98-4640	6	Screw-Cap
5	98-4644	1	Plate-Cover
6	105-9762	6	Washer
7	100-3182	2	Shim Kit
8	98-4639	2	Bearing-Cone
9	94-3646	1	Key
10	100-3175	1	Camplate
11	76-6070	1	Rotating Kit
13	100-3180	1	Valve-Plate
15	76-6150	2	Pin-Dowel
16	105-3813	1	Endcover Sub ASM
16:1	94-6368	1	Bearing
●16:2		1	Pin-Roll
20	105-3812	2	Valve-Check
21	105-3811	1	Valve-Bypass
22	76-6170	2	Capscrew
23	76-6160	2	Capscrew
25	98-4645	1	Plate-Cover
29	100-3176	1	Housing ASM
29:1	94-6363	1	Bearing
31	252-71	2	Washer-Thrust

Ref	Part No.	Qty.	Description
32	252-66	1	Bearing-Thrust
33	33-3720	1	Washer
39	98-4635	1	Insert-Plate, Cam
42	74-9040	1	Coupler
43	105-3844	1	Seal Repair Kit
43:1	100-3179	2	O-Ring
43:2	33-4930	1	Gasket-Housing
43:4	32151-29	2	Ring-Retaining
43:5	104-4861	1	Seal-Shaft
43:6	32151-13	1	Ring-Retaining
●43:9		1	O-Ring
●43:10		1	Seal-Shaft

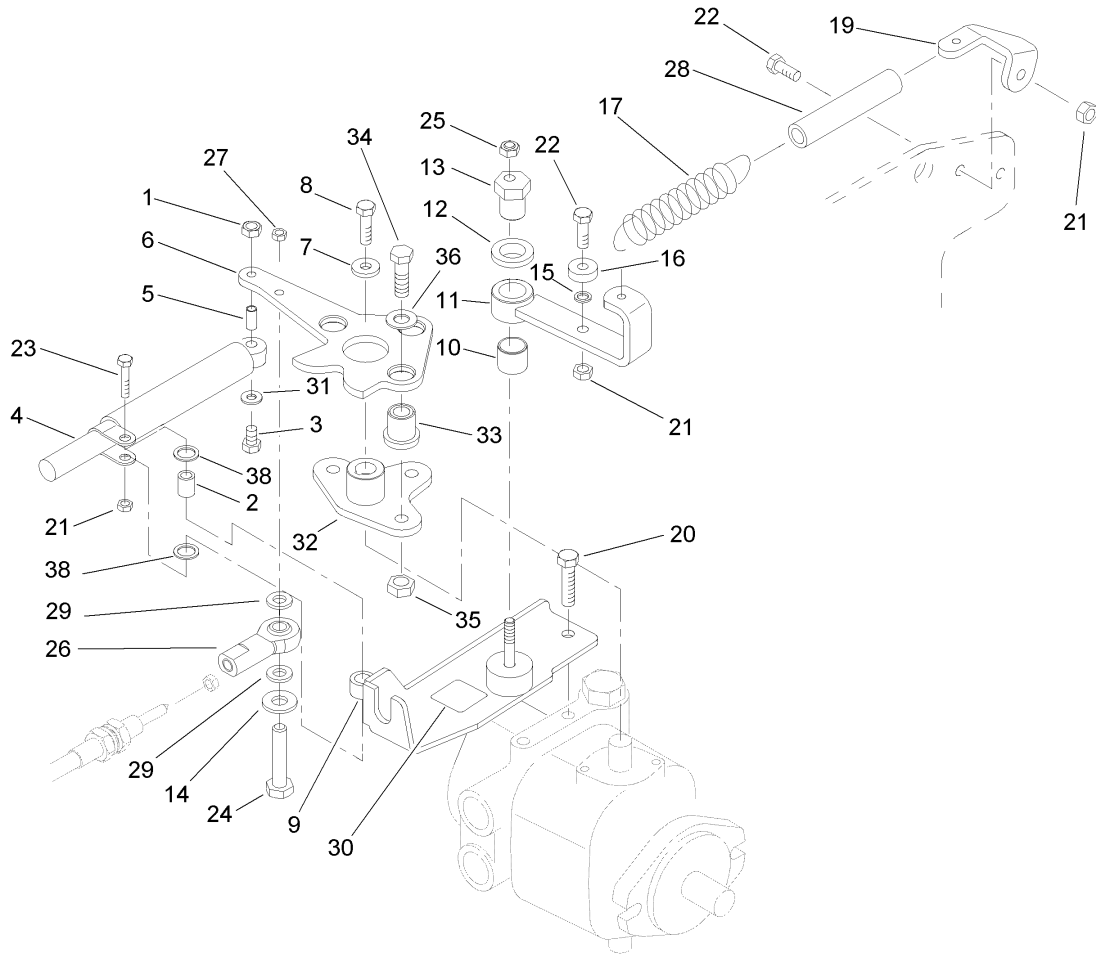

Neutral System Assembly

Ref	Part No.	Qty.	Description
1	33023-00	1	Nut-Lock
2	94-8197	1	Tube-Pivot
3	33113-035	1	Screw-HH
4	76-8870	1	Lever Damper ASM
5	94-1312	1	Spacer-Pivot
6	94-3488-03	1	Lever-Pump
7	88-7200	1	Washer-Flat
8	3210-6	1	Screw-HH
9	100-9846	1	Support-Cable
10	94-9609	1	Bushing-Straight
11	94-4527	1	Arm-Neutral
12	3-6498	1	Washer-Thrust
13	93-2111	1	Stud-Traction
14	3256-22	1	Washer-Flat
15	75-5470	1	Spacer-Bearing
16	251-259	1	Bearing-Ball
17	99-4254	1	Spring-Extension
19	99-4276	1	Bracket-Spring
20	323-4	2	Screw-HH
21	33024-00	3	Nut-Lock
22	33114-025	2	Screw-HH
23	33114-030	1	Screw-HH
24	321-8	1	Screw-HH
25	3296-29	1	Nut-Lock, NI

Ref	Part No.	Qty.	Description
26	2411-41	1	Joint-Ball
27	3296-42	1	Nut-Lock, NI
28	99-4251	1	Hose-Dampener
29	33093-00	2	Washer-Flat
30	93-9051	1	Decal-Bolt, Eccentric
31	3256-22	1	Washer-Flat
32	94-3486	1	Plate
33	63-9750	3	Mount
34	33115-035	3	Screw-HH
35	33025-00	3	Nut-Lock
36	2844	3	Washer
38	94-8196	2	Washer-Nylon

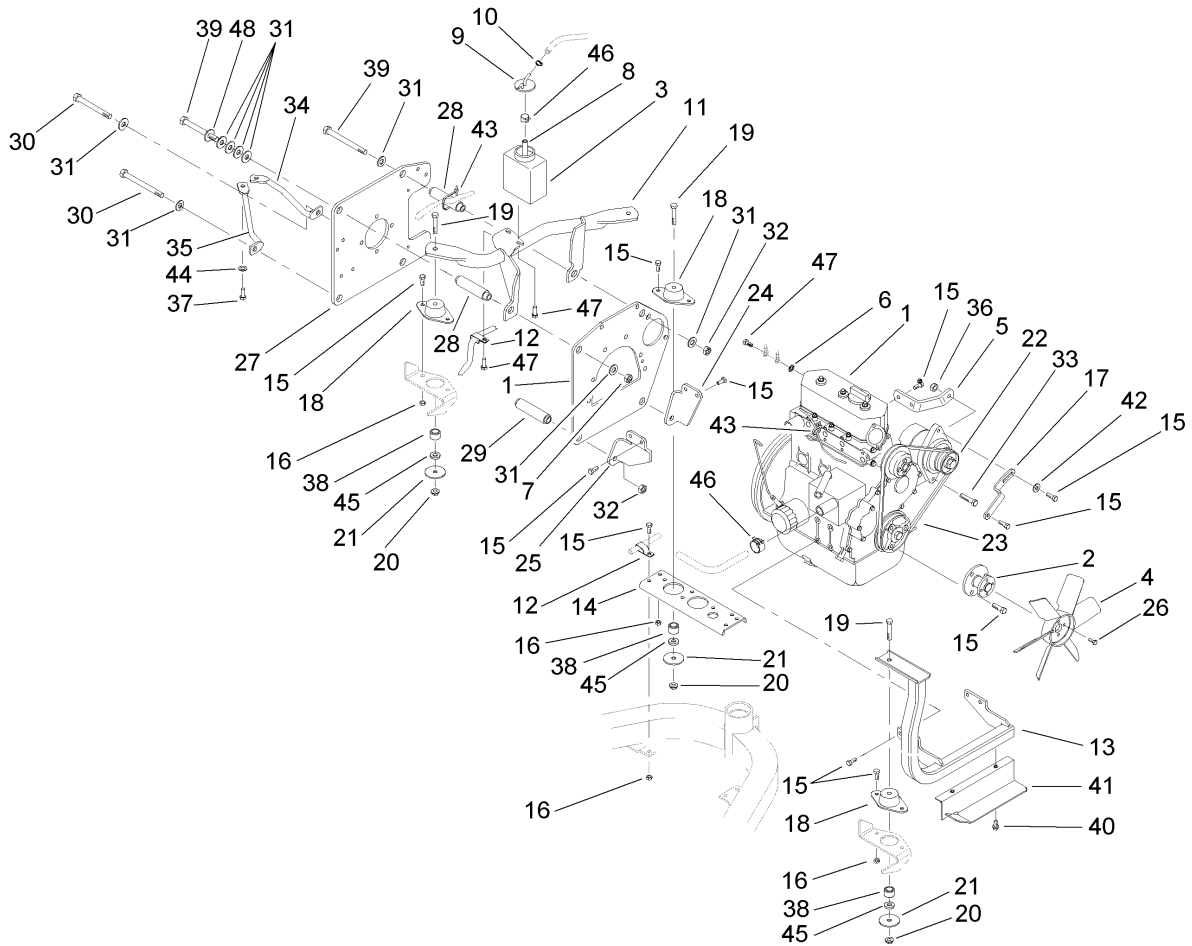

Engine Installation Assembly

Ref	Part No.	Qty.	Description
1	99-1481	1	Engine
2	99-1495	1	Adapter-Fan
3	93-2049	1	Tank-Overflow
4	93-2090	1	Fan-Engine
5	93-2445	1	Bracket-Alternator, Upper
6	3254-2	1	Washer-Lock, Internal
7	51-2070	1	Nut
8	108-3283	1	Hose-Fuel
9	93-2048	1	Cap-Tank, Overflow
10	2412-108	1	Clamp-Worm
11	100-3190-03	1	Engine Mount ASM
12	92-5753	2	Clamp-Hose
13	99-1473-03	1	Mount-Engine, Front
14	93-2020-01	1	Bracket-Support
15	33114-020	26	Screw-HH
16	33024-00	4	Nut-Lock
17	93-2446	1	Bracket-Alternator, Lower
18	83-1030	3	Mount-Engine
19	323-11	3	Screw-HH
20	3290-357	3	Nut-HHF, Whiz
21	83-1040	3	Washer-Flat
22	99-9209	1	Alternator
23	99-8153	1	Belt-V
24	99-4189-03	1	Bracket-Engine, LH

Ref	Part No.	Qty.	Description
25	99-4188-03	1	Bracket-Engine, RH
26	33113-016	4	Screw-HH
27	99-4190-03	1	Plate-Pump
28	93-2588	2	Spacer-Upper
29	93-2174	2	Spacer
30	33116-130	2	Screw-HH
31	87-7270	9	Washer-Thrust
32	33026-00	3	Nut-Lock
33	33115-050	1	Screw-HH
34	99-4240	1	Brace-Wireform, LH
35	99-4238	1	Brace-Wireform, RH
36	33025-00	1	Nut-Lock
37	323-4	2	Screw-HH
38	94-4538	3	Spacer-Mount
39	33116-120	2	Screw-HH
40	32104-32	2	Screw-HH
41	94-8156-03	1	Deflector-Fan
42	3256-3	1	Washer-Flat
43	3290-378	2	Tie-Cable
44	3256-24	2	Washer-Flat
45	66-6480	3	Washer
46	92-2379	2	Clamp-Hose
47	33114-016	3	Screw-HH
48	73-0040	1	Washer-Thrust

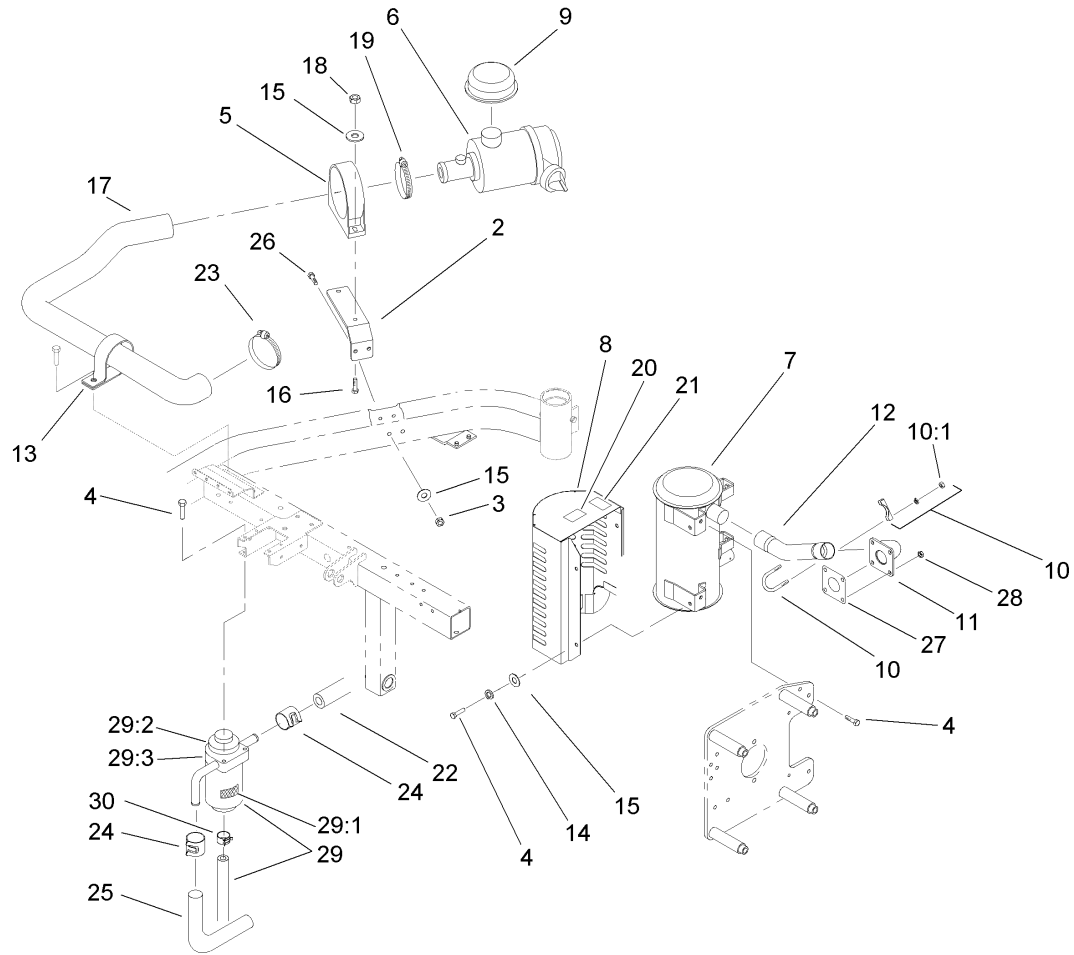

Air Cleaner and Exhaust Assembly

Ref	Part No.	Qty.	Description
2	99-4203-03	1	Bracket-Cleaner, Air
3	33024-00	2	Nut-Lock
4	33114-020	8	Screw-HH
5	95-5806	1	Bracket-Mounting
6	95-5805	1	Air Cleaner ASM
7	94-8153	1	Muffler
8	94-8182-03	1	Shield-Muffler ASM
9	46-7510	1	Hood-Inlet, Air
10	2112-9	2	Clamp
10:1	32128-20	2	Nut-HF
11	99-1472	1	Plate-Exhaust
12	99-1494	1	Pipe-Exhaust
13	2412-107	1	Clamp-R
14	3253-4	4	Washer-Lock
15	3256-23	4	Washer-Flat
16	322-16	2	Screw-HH
17	99-4204	1	Hose-Cleaner, Air
18	3296-29	2	Nut-Lock, NI
19	2412-92	1	Clamp-Hose
20	93-8069	1	Decal-Surface, Hot
21	93-7275	1	Decal-Fluid, Starting
22	110-4112	1	Hose-Fuel
23	2412-130	1	Clamp-Hose
24	92-2379	2	Clamp-Hose

Ref	Part No.	Qty.	Description
25	110-4007	1	Hose-Fuel
26	33114-080	2	Screw-HH
27	99-9179	1	Gasket-Exhaust
28	99-9176	4	Nut-Hex
29	100-3191	1	Separator-Fuel
29:1	100-3192	1	Element-Filter, Fuel
29:2	100-6409	1	Sensor-Filter, Fuel
29:3	100-6408	1	Cover-Filter
30	94-8189	1	Clamp-Hose

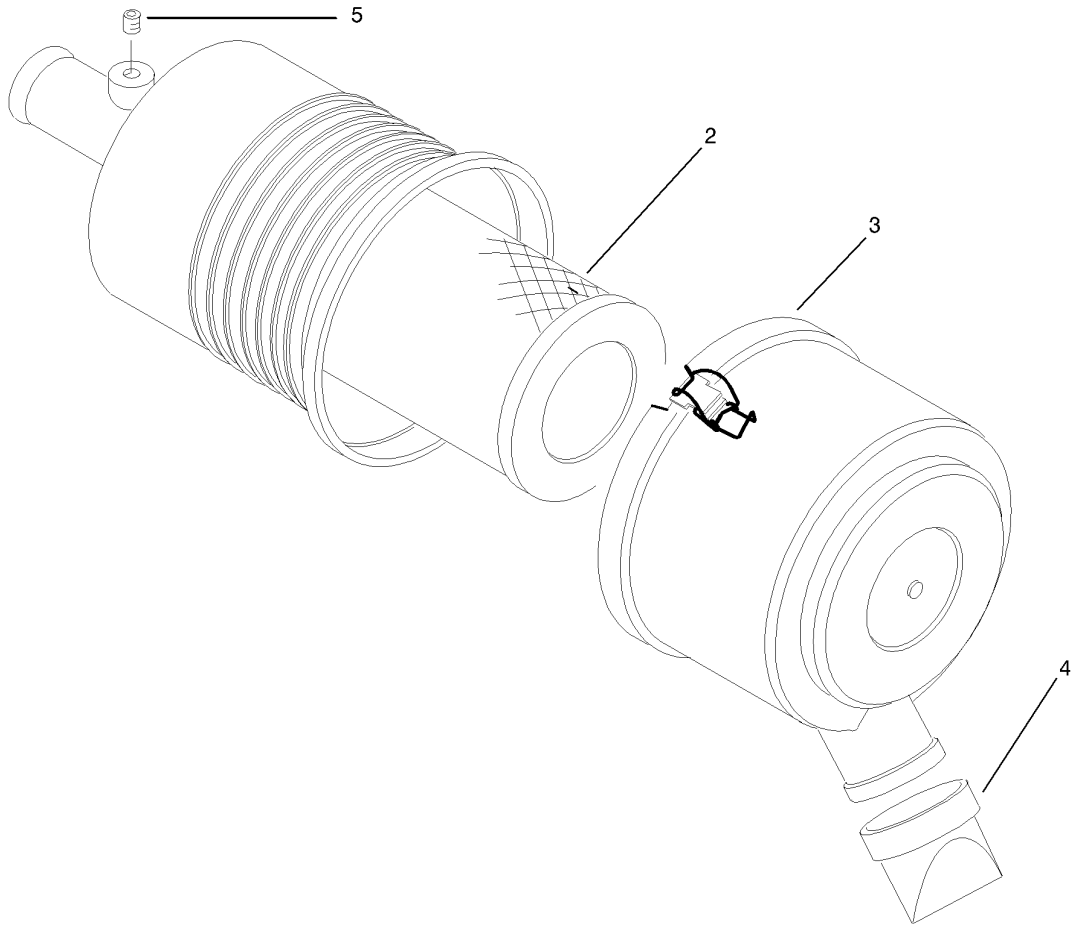

Air Cleaner Assembly No. 95-5805

Ref	Part No.	Qty.	Description
2	108-3811	1	Filter-Air
3	94-3652	1	Cover ASM
4	87-9400	1	Valve-Vacuator
5	285-17	1	Plug-Pipe

Ref	Part No.	Qty.	Description

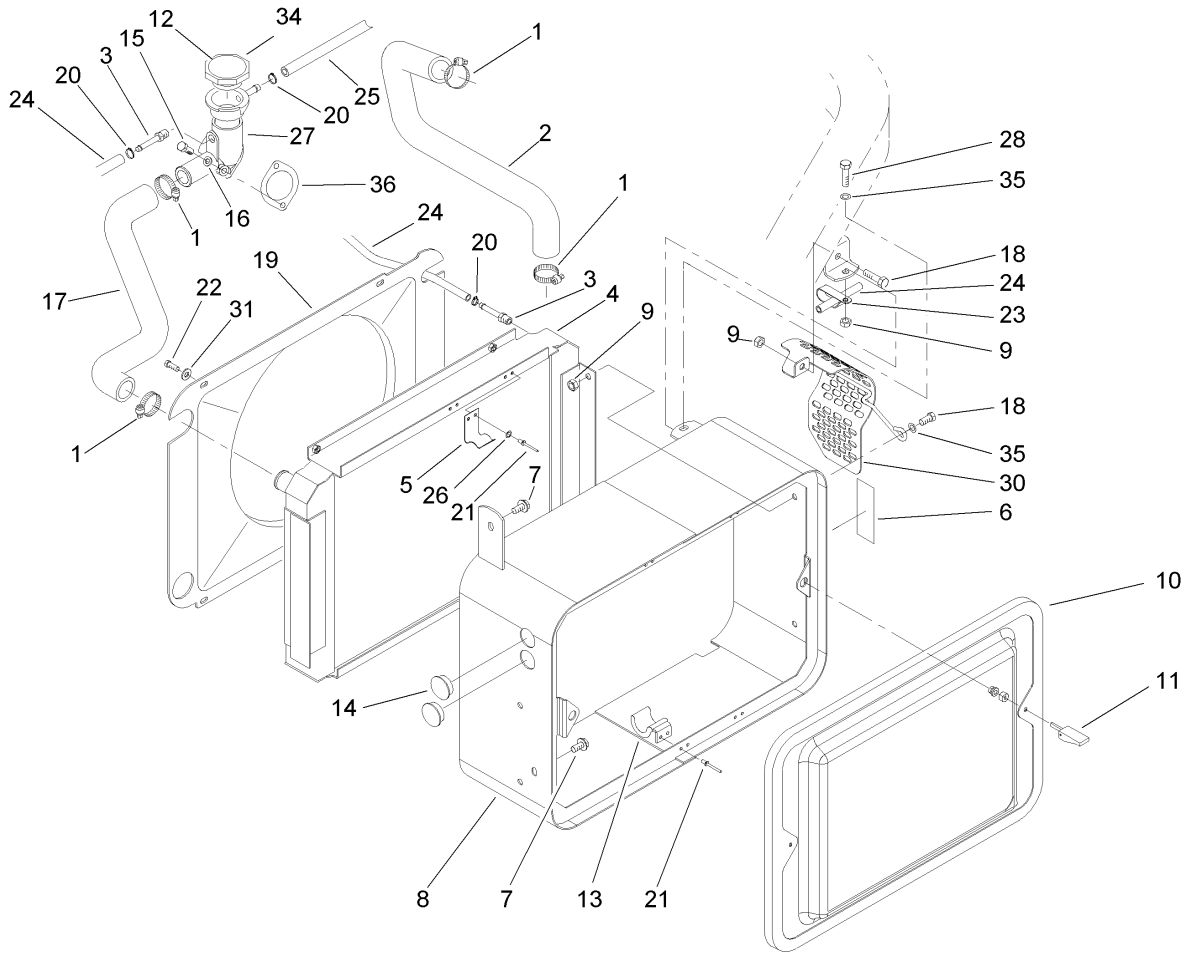

Radiator Assembly

Ref	Part No.	Qty.	Description
1	2412-34	4	Clamp-Hose
2	99-1469	1	Hose-Radiator
3	304-73	2	Connector-Hose
4	99-8193	1	Radiator
5	104-7736	1	Bracket-Cooler, Upper
6	93-6681	1	Decal-Warning, Fan
7	32104-32	2	Screw-HH
8	106-9056-01	1	Support ASM-Radiator
9	33024-00	6	Nut-Lock
10	100-3172-03	1	Screen ASM
11	74-5950	2	Latch-Swell
12	106-5976	1	Decal-Warning
13	93-2424	2	Bracket-Cooler, Lower
14	94-4528	2	Plug
15	33113-025	2	Screw-HH
16	3253-3	2	Washer-Lock
17	93-2018	1	Hose-Radiator
18	33114-020	5	Screw-HH
19	93-2320	1	Shroud-Fan
20	2412-108	3	Clamp-Worm
21	3269-15	6	Rivet
22	33113-016	4	Screw-HH
23	92-5753	1	Clamp-Hose
24	109-0281	1	Hose-Fuel

Ref	Part No.	Qty.	Description
25	110-4112	1	Hose-Fuel
26	3269-6	2	Washer
27	93-2448	1	Thermostat Housing ASM
28	33114-025	1	Screw-HH
30	100-3164-03	1	Guard-Alternator
31	3256-22	4	Washer-Flat
34	66-3240	1	Cap-Radiator
35	3256-23	2	Washer-Flat
36	99-9163	1	Gasket-Outlet

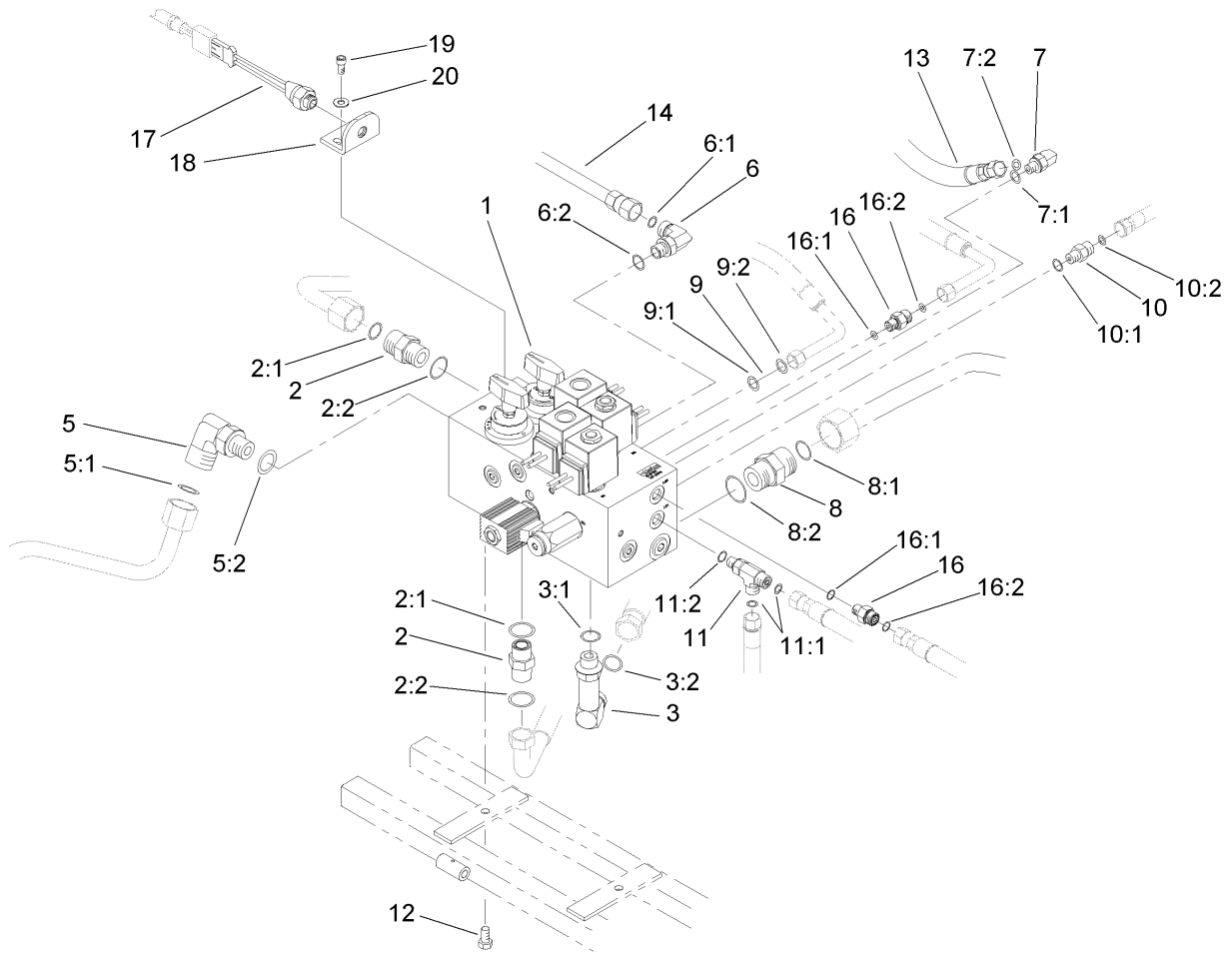

Manifold Block Installation Assembly

Ref	Part No.	Qty.	Description
1	107-2570	1	Mow/Lift Manifold ASM
2	340-7	2	Adapter
2:1	237-65	1	O-Ring
2:2	237-80	1	O-Ring
3	99-6160	1	Fitting-Elbow, 90 DEG
3:1	237-30	1	O-Ring
3:2	237-79	1	O-Ring
5	340-17	1	Fitting-HYD, 90 DEG
5:1	237-65	1	O-Ring
5:2	237-80	1	O-Ring
6	340-77	1	Fitting-HYD, 90 DEG
6:1	237-22	1	O-Ring
6:2	237-42	1	O-Ring
7	340-132	1	Fitting-HYD, 90 DEG
7:1	237-78	1	O-Ring
7:2	237-21	1	O-Ring
8	340-9	1	Fitting-HYD, Straight
8:1	237-58	1	O-Ring
8:2	237-81	1	O-Ring
9	340-92	1	Fitting-HYD, Straight
9:1	237-78	1	O-Ring
9:2	237-21	1	O-Ring
10	95-1639	1	Fitting-HYD
10:1	237-78	1	O-Ring

Ref	Part No.	Qty.	Description
10:2	237-21	1	O-Ring
11	340-140	1	Adapter-Tee
11:1	237-21	2	O-Ring
11:2	237-78	1	O-Ring
12	33114-016	2	Screw-HH
13	93-2271	1	HYD Hose ASM
14	105-9790	1	Hose ASM
16	95-1639	2	Fitting-HYD
16:1	237-78	1	O-Ring
16:2	237-21	1	O-Ring
17	72-4320	1	Switch-Ball
18	94-1357	1	Bracket-Backlap
19	3274-52	2	Screw-HSH
20	3256-22	2	Washer-Flat

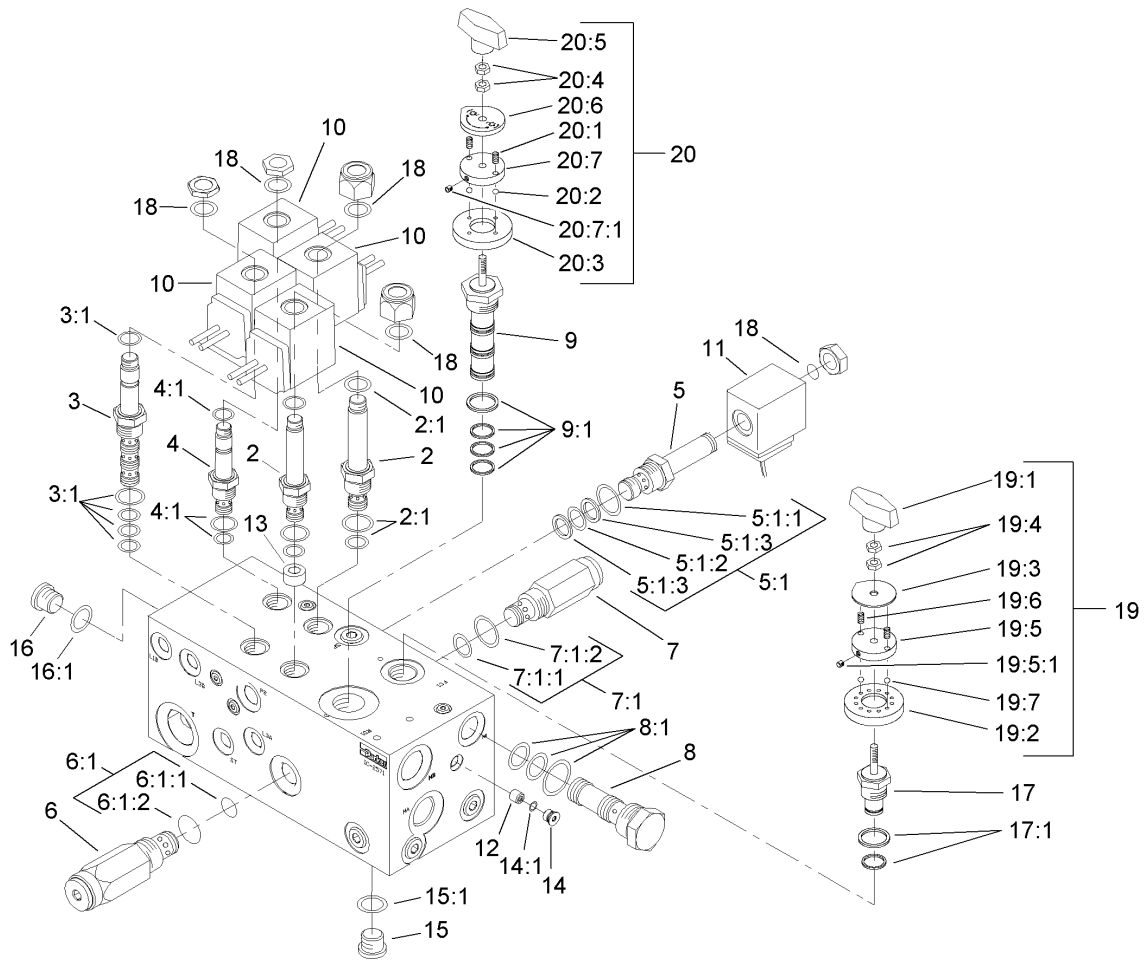

Mow/Lift Manifold Assembly No. 107-2570

Ref	Part No.	Qty.	Description
2	93-7494	2	Cartridge
2:1	95-5645	1	Seal Kit
2:1:1		1	O-Ring
2:1:2		1	O-Ring
2:1:3		1	P-Ring
3	94-2627	1	Cartridge
3:1	95-5642	1	Seal Kit
3:1:1		1	O-Ring
3:1:2		1	O-Ring
3:1:3		1	O-Ring
3:1:4		1	Ring-Boss, Low Compression
4	92-6315	1	Cartridge-Poppet, N.C.
4:1	95-5645	1	Seal Kit
4:1:1		1	O-Ring
4:1:2		1	O-Ring
4:1:3		1	P-Ring
5	106-9087	1	Spool-Type, Stem
5:1	105-3334	1	Seal Kit
5:1:1		1	O-Ring
5:1:2		1	O-Ring
5:1:3		2	Ring-Backup
6	95-1601	1	Cartridge-Relief
6:1	95-5645	1	Seal Kit
6:1:1		1	O-Ring

Ref	Part No.	Qty.	Description
6:1:2		1	O-Ring
6:1:3		1	P-Ring
7	94-6351	1	Cartridge-Relief
7:1	95-5645	1	Seal Kit
7:1:1		1	O-Ring
7:1:2		1	O-Ring
7:1:3		1	P-Ring
8	95-5634	1	Cartridge-Logic, Spool
8:1	95-5641	1	Seal Kit
9	94-3657	1	Spool ASM
9:1	106-1091	1	Seal Kit
10	88-9190	4	Solenoid Coil Kit
11	106-9086	1	Coil-Solenoid
12	106-9084	1	Plug-Orifice
13	106-9083	1	Plug-Orifice
14	353-991	1	Plug-Hex, Hollow
14:1	237-156	1	O-Ring
15	353-989	8	Plug-Hex, Hollow
15:1	237-42	1	O-Ring
16	353-988	1	Plug-Hex
16:1	237-79	1	O-Ring
17	94-8175	1	Control-Flow, Rotary
17:1	106-1090	1	Seal Kit
18	94-5438	10	Seal-Washer

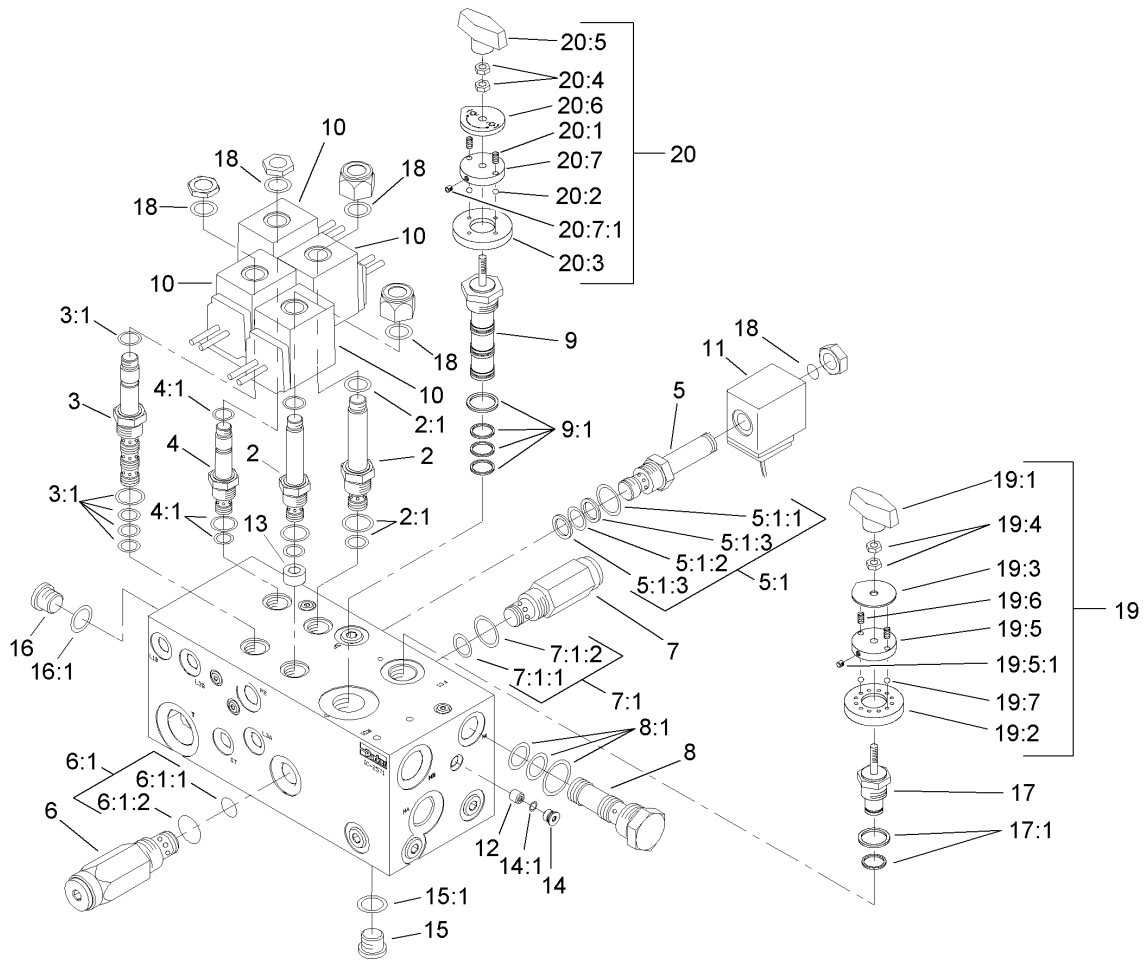

Mow/Lift Manifold Assembly No. 107-2570 (continued)

Ref	Part No.	Qty.	Description
19	94-3660	1	Detent Kit
19:1	94-5020	1	Knob ASM
19:2	94-5025	1	Plate-Locating
19:3	94-5026	1	Plate-Indicator
19:4	3218-1	2	Nut-Jam
19:5	94-5023	1	Plate-Detent
19:5:1	3245-36	1	Screw-Set, HSH
19:6	94-5027	2	Spring
19:7	255-13	2	Ball-Steel, Stainless
20	94-6378	1	Detent Kit
20:1	94-5027	2	Spring
20:2	255-13	2	Ball-Steel, Stainless
20:3	94-5021	1	Plate-Locating
20:4	3218-1	2	Nut-Jam
20:5	94-5020	1	Knob ASM
20:6	99-3543	1	Plate-Indicator
20:7	94-5023	1	Plate-Detent
20:7:1	3245-36	1	Screw-Set, HSH
21	99-3543	1	Plate-Indicator

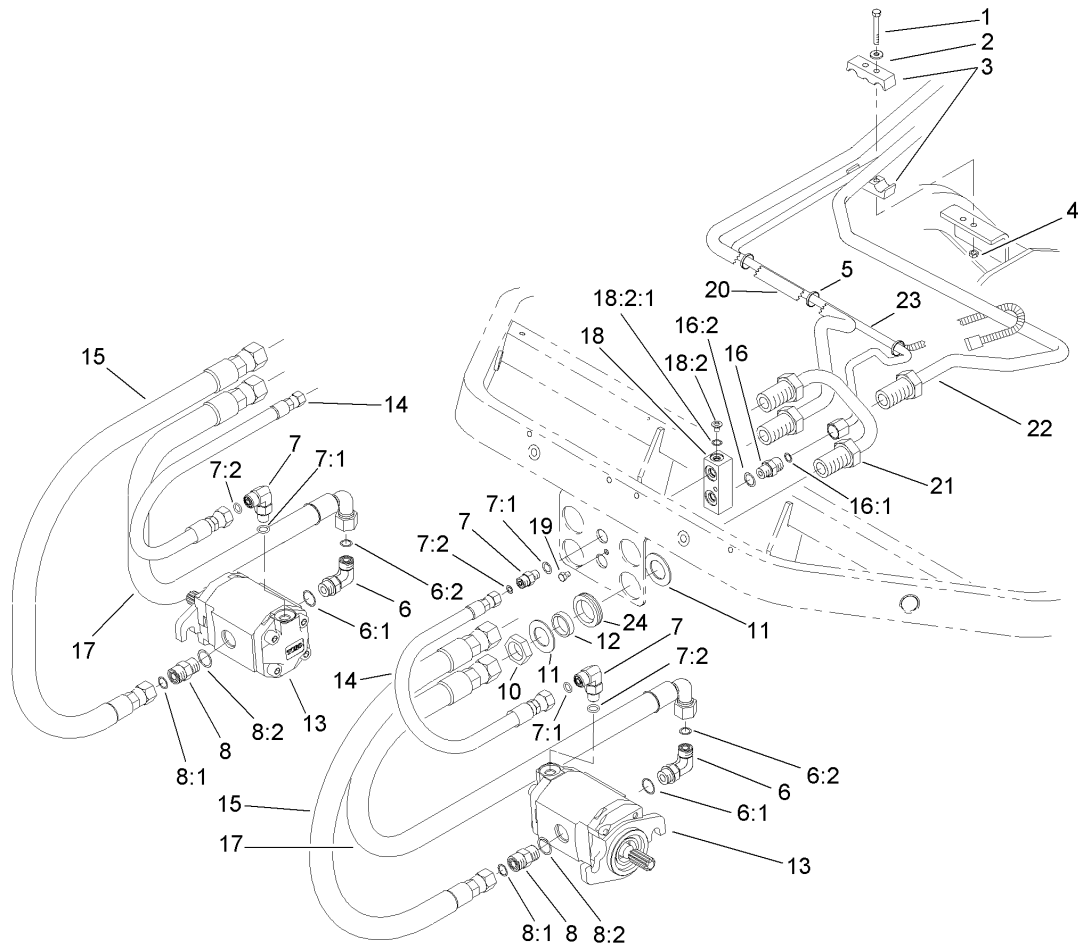

Front Bulkhead and Reel Motor Assembly

Ref	Part No.	Qty.	Description
1	33113-050	2	Screw-HH
2	3256-1	2	Washer-Flat
3	93-2509	2	Clamp-Tube
4	33023-00	2	Nut-Lock
5	3290-378	3	Tie-Cable
6	340-98	2	Fitting-HYD, 90 DEG
6:1	237-79	1	O-Ring
6:2	237-30	1	O-Ring
7	340-132	2	Fitting-HYD, 90 DEG
7:1	237-78	1	O-Ring
7:2	237-21	1	O-Ring
8	340-4	2	Fitting-HYD, Straight
8:1	237-30	1	O-Ring
8:2	237-79	1	O-Ring
10	340-74	2	Locknut-Bulkhead
11	69-9010	4	Washer
12	69-9000	2	Spacer
13	100-6426	2	HYD Motor ASM
14	106-9674	2	HYD Hose ASM
15	95-2908	2	Hose ASM
16	340-2	1	Fitting-HYD, Straight
16:1	237-22	1	O-Ring
16:2	237-42	1	O-Ring
17	95-2909	2	Hose ASM

Ref	Part No.	Qty.	Description
18	93-2238	1	T-Block
18:2	353-991	1	Plug-Hex, Hollow
18:2:1	237-156	1	O-Ring
19	33113-008	1	Screw-HH
20	94-1318	1	Tube-HYD
21	94-1319	1	Tube-HYD
22	94-1320	1	Tube-HYD
23	94-1321	1	Tube-HYD
24	240-3	2	Grommet-Rubber

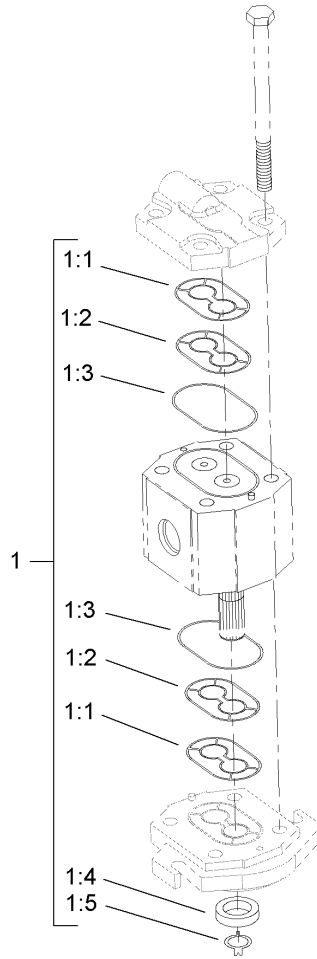

Reel Motor Assembly No. 100-6426

Ref	Part No.	Qty.	Description				
1	105-9758	1	Seal Kit				
② 1:1		2	Seal-Extrusion, Anti				
② 1:2		2	Seal-Pressure				
② 1:3		2	O-Ring				
② 1:4		1	Seal-Shaft				
② 1:5		1	Washer-Backup				

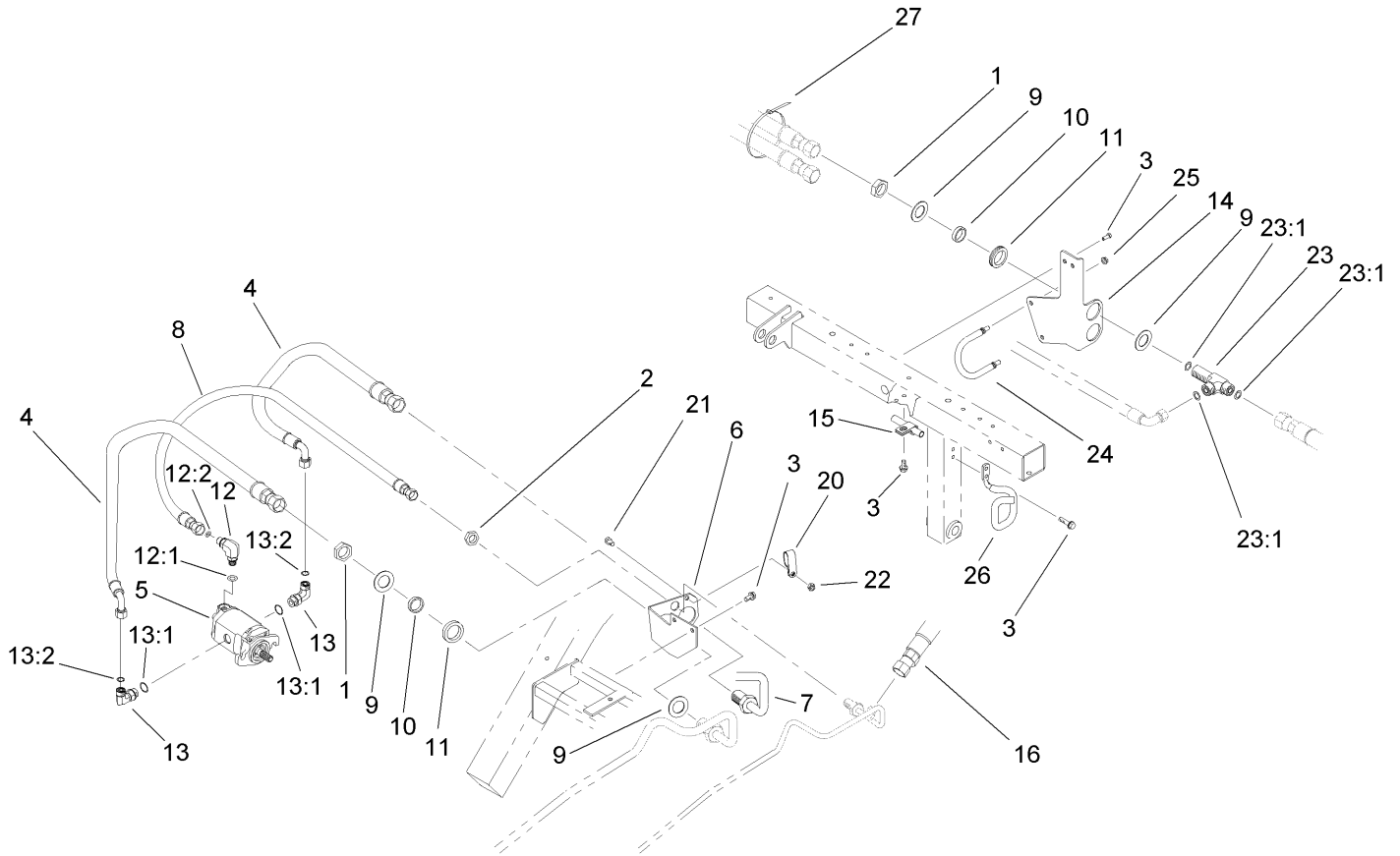

Rear Bulkhead and Reel Motor Assembly

Ref	Part No.	Qty.	Description
1	340-74	4	Locknut-Bulkhead
2	340-70	1	Nut-Lock
3	32104-32	7	Screw-HH
4	95-2907	2	Hose ASM
5	100-6426	1	HYD Motor ASM
6	94-1316	1	Bracket-Bulkhead
7	94-1317	1	Tube-HYD
8	105-5405	1	Hose ASM
9	69-9010	8	Washer
10	69-9000	4	Spacer
11	240-3	4	Grommet-Rubber
12	340-132	1	Fitting-HYD, 90 DEG
12:1	237-78	1	O-Ring
12:2	237-21	1	O-Ring
13	340-98	2	Fitting-HYD, 90 DEG
13:1	237-79	1	O-Ring
13:2	237-30	1	O-Ring
14	99-4222-03	1	Bracket-Hose
15	2412-4	1	Clamp
16	110-4008	1	Hose ASM-HYD
20	2412-137	1	Clamp-Tube
21	33114-020	1	Screw-HH
22	33024-00	1	Nut-Lock
23	94-5350	2	Tee-Bulkhead

Ref	Part No.	Qty.	Description
23:1	237-65	3	O-Ring
24	99-4221	1	Retainer-Hose
25	3296-29	2	Nut-Lock, NI
26	94-5352	1	Retainer-Hose
27	3290-378	1	Tie-Cable

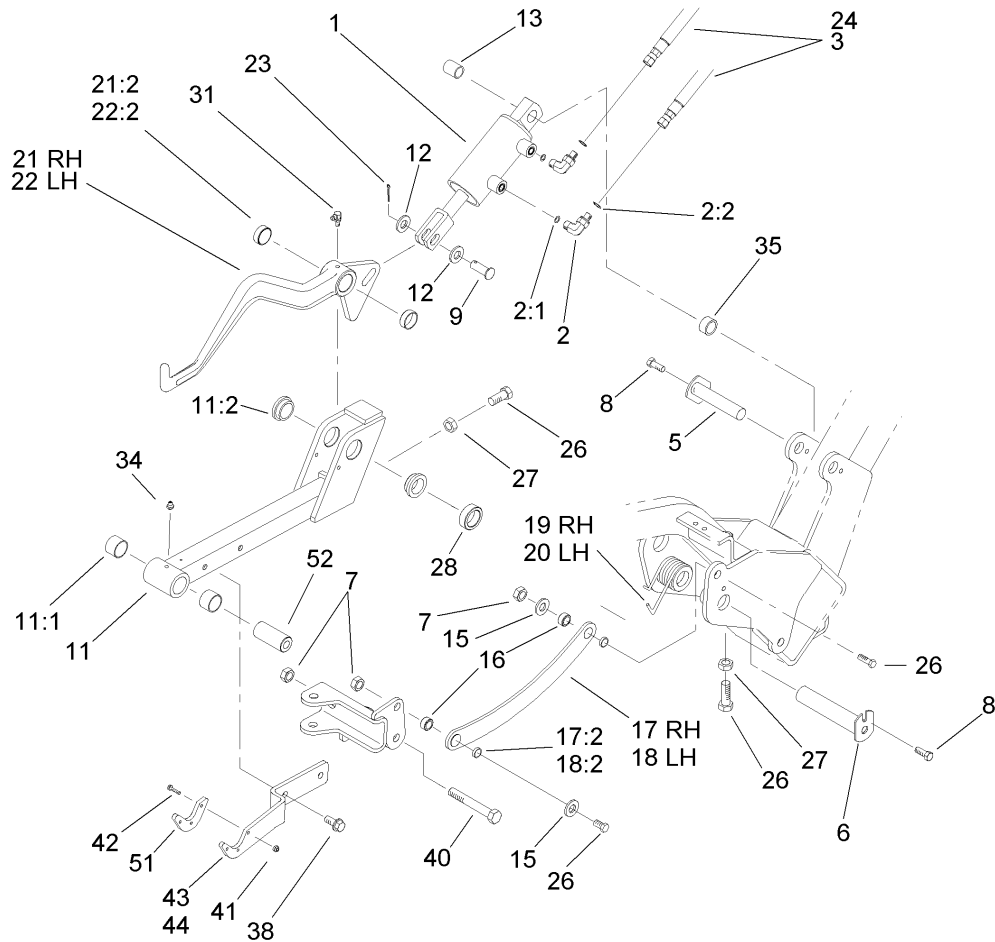

Left Hand and Right Hand Lift Arm Assembly

Ref	Part No.	Qty.	Description
1	105-3821	2	HYD Cylinder ASM
2	340-132	4	Fitting-HYD, 90 DEG
2:1	237-78	1	O-Ring
2:2	237-21	1	O-Ring
3	108-6505	2	Hose ASM
5	10-6060	2	Pin-Pivot, Ram
6	94-8198	2	Pin
7	3296-25	6	Nut-Lock, NI
8	32104-32	4	Screw-HH
9	283-68	2	Pin-Clevis
11	99-4115	2	Front Lift Frame ASM
11:1	98-4166	2	Bushing
11:2	94-9610	2	Bushing-Flange
12	33096-00	4	Washer-Flat
13	105-3838	2	Spacer
15	3256-26	4	Washer-Flat
16	99-4201	4	Tube-Spacer
17	99-4258	1	RH Link Bracket ASM
17:2	99-4243	2	Bushing-Flange
18	99-4260	1	LH Link Bracket ASM
18:2	99-4243	2	Bushing-Flange
19	105-3809	1	Spring-Torsion, RH
20	105-3818	1	Spring-Torsion, LH
21	99-4213	1	RH Lift Arm ASM

Ref	Part No.	Qty.	Description
21:2	92-8995	2	Bushing
22	99-4212	1	LH Lift Arm ASM
22:2	92-8995	2	Bushing
23	3272-11	2	Pin-Cotter
24	93-2254	2	HYD Hose ASM
26	325-6	7	Screw-HH
27	3218-5	3	Nut-Jam
28	93-2384	2	Spacer-Carrier
31	302-60	2	Fitting-Grease, 90 DEG
34	302-5	2	Fitting-Grease
35	74-3730	2	Spacer-Spindle, Rear
38	32144-69	4	Screw-HH
40	325-14	2	Screw-HH
41	3296-54	6	Nut-Lock
42	3250-17	6	Screw-PPH
43	99-4111-01	1	Plate-Transport, 1 And 3
44	99-4112-01	1	Plate-Transport, 2
51	99-4225	2	Pad-Wear
52	99-4072	2	Spacer-Frame, Pull

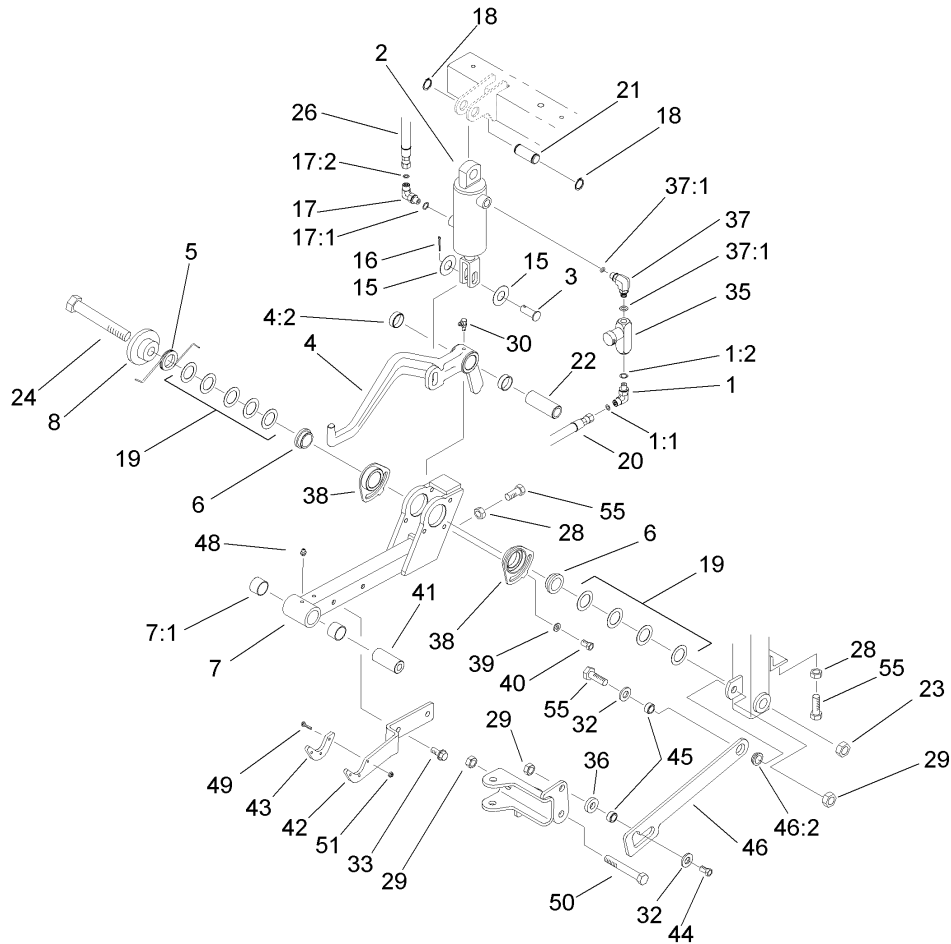

Center Lift Arm Assembly

Ref	Part No.	Qty.	Description
1	340-132	1	Fitting-HYD, 90 DEG
1:1	237-78	1	O-Ring
1:2	237-21	1	O-Ring
2	105-3820	1	HYD Cylinder ASM
3	283-68	1	Pin-Clevis
4	99-4126	1	Center Lift Arm ASM
4:2	92-8995	2	Bushing
5	105-9781	1	Spring-Torsion
6	98-2197	2	Bushing-Flange
7	99-4116	1	Rear Lift Frame ASM
7:1	98-4166	2	Bushing
8	105-9779	1	Guide-Spring
15	33096-00	2	Washer-Flat
16	3272-11	1	Pin-Cotter
17	340-132	1	Fitting-HYD, 90 DEG
17:1	237-78	1	O-Ring
17:2	237-21	1	O-Ring
18	32120-72	2	Ring-Snap
19	63-2290	9	Washer-Thrust
20	93-2258	1	HYD Hose ASM
21	94-3452	1	Pin
22	94-8199	1	Tube-Pivot
23	3296-53	1	Nut-Lock, NI
24	327-25	1	Screw-HH

Ref	Part No.	Qty.	Description
26	106-7981	1	Hose-HYD
28	3218-5	2	Nut-Jam
29	3296-25	3	Nut-Lock, NI
30	302-60	1	Fitting-Grease, 90 DEG
32	3256-26	2	Washer-Flat
33	32144-69	2	Screw-HH
35	93-7489	1	Orifice Valve ASM
36	99-4248	1	Spacer
37	95-2927	1	Fitting-Elbow
37:1	237-78	2	O-Ring
38	98-4618	2	Bushing-Eccentric
39	3256-74	2	Washer-Flat
40	33114-016	2	Screw-HH
41	99-4072	1	Spacer-Frame, Pull
42	99-4111-01	1	Plate-Transport, 1 And 3
43	99-4225	1	Pad-Wear
44	325-7	1	Screw-HH
45	99-4201	2	Tube-Spacer
46	99-4246	1	Link Bracket ASM
46:2	99-4243	1	Bushing-Flange
48	302-5	1	Fitting-Grease
49	3250-17	3	Screw-PPH
50	325-14	1	Screw-HH
51	3296-54	3	Nut-Lock

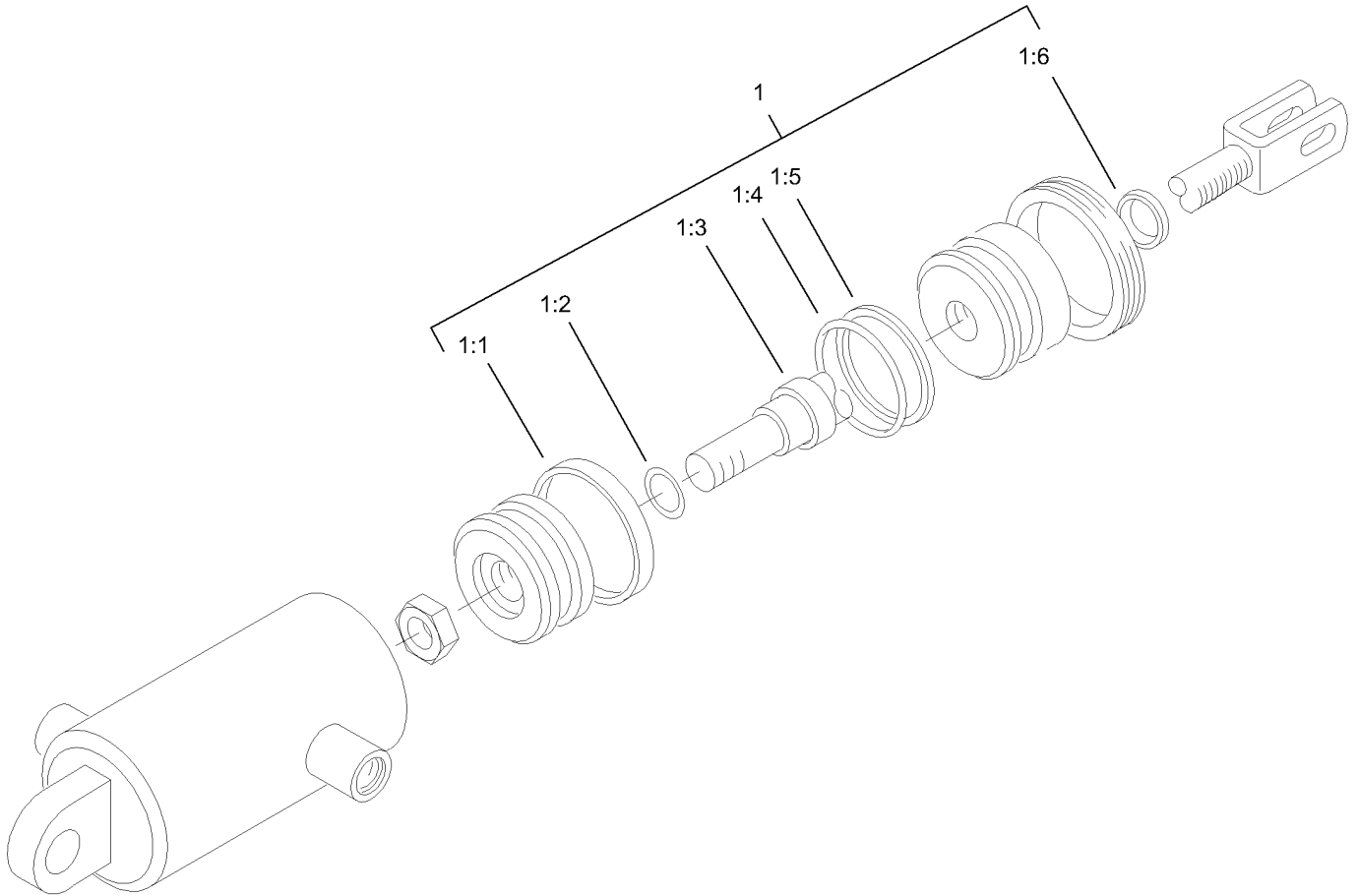

Hydraulic Cylinder Assembly No. 105-3820

Ref	Part No.	Qty.	Description
1	105-3836	1	Seal Kit
● 1:1		1	T-Seal
● 1:2		1	O-Ring
● 1:3		1	Seal-Rod
● 1:4		1	O-Ring
● 1:5		1	Backup
● 1:6		1	Seal-Dust

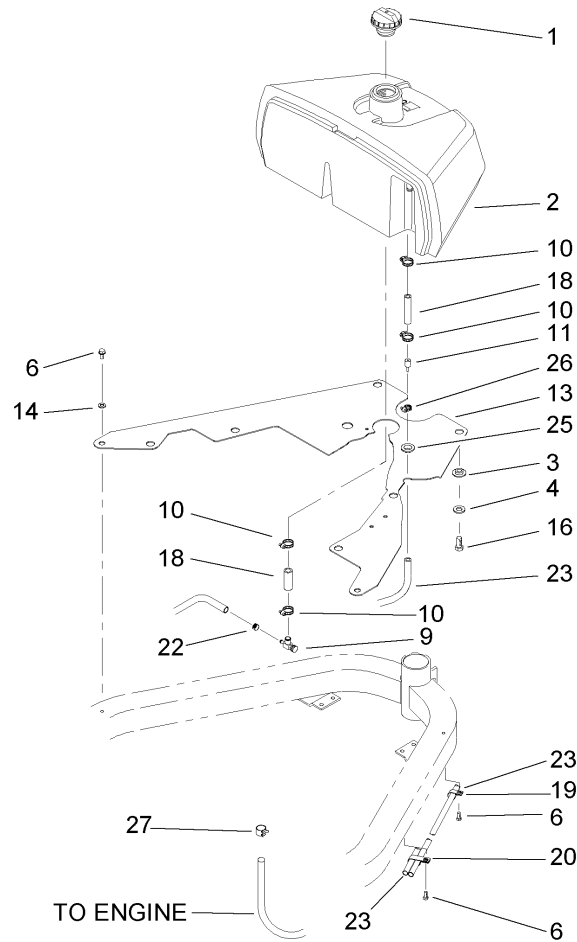

Fuel System Assembly

Ref	Part No.	Qty.	Description
1	93-3102	1	Cap-Fuel
2	93-2225	1	Tank-Fuel
3	240-11	3	Bushing-Flange
4	93-4637	3	Washer-Flat
6	32104-32	5	Screw-HH
9	56-2520	1	Fitting-Shut Off, Fuel
10	2412-36	4	Clamp-Hose
11	93-2299	1	Fitting-Fuel
13	94-1364-03	1	Plate ASM
14	3256-23	2	Washer-Flat
16	33115-020	3	Screw-HH
18	106-1128	2	Hose-Fuel
19	2412-41	1	Clamp
20	92-5753	1	Clamp-Hose
22	92-2379	1	Clamp-Hose
23	110-3958	1	Hose-Fuel
25	237-124	1	Grommet
26	2412-108	1	Clamp-Worm
27	94-8189	1	Clamp-Hose

--	--	--	--

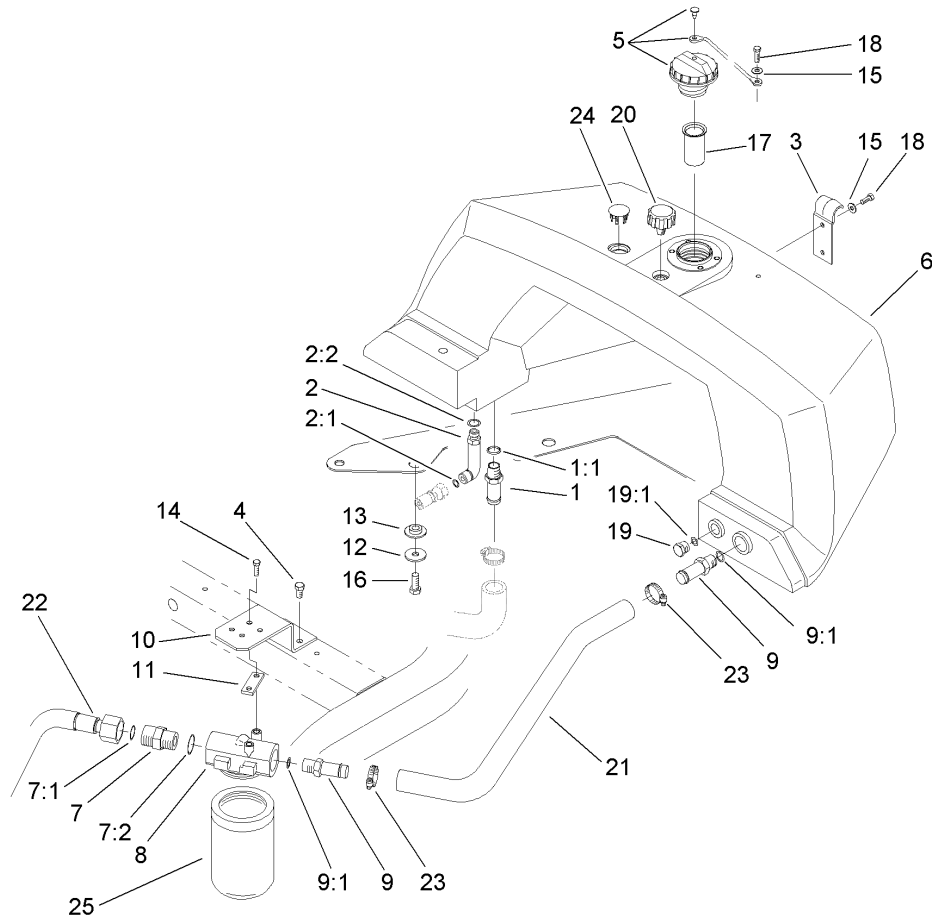

Hydraulic Tank and Filter Assembly

Ref	Part No.	Qty.	Description
1	354-78	1	Connector-Hose
1:1	237-146	1	O-Ring
2	69-4320	1	Fitting-90 DEG
2:1	237-22	1	O-Ring
2:2	237-42	1	O-Ring
3	93-2438	1	Clamp-Tank, Fuel
4	32104-32	2	Screw-HH
5	93-7160	1	Cap-Oil, HYD
6	93-2235	1	Tank-HYD
7	340-9	1	Fitting-HYD, Straight
7:1	237-58	1	O-Ring
7:2	237-81	1	O-Ring
8	92-5821	1	Filter Head ASM
9	354-73	2	Fitting
9:1	237-81	1	O-Ring
10	105-9793-03	1	Mount-Filter, Oil
11	105-4309	1	Plate-Filter
12	93-4637	4	Washer-Flat
13	240-11	4	Bushing-Flange
14	321-5	2	Screw-HH
15	3256-1	3	Washer-Flat
16	33115-020	4	Screw-HH
17	93-2275	1	Screen-Filler
18	33113-016	3	Screw-HH

Ref	Part No.	Qty.	Description
19	353-988	1	Plug-Hex
19:1	237-79	1	O-Ring
20	68-6150	1	Breather
21	94-9607	1	Hose-Return
22	94-4518	1	Tube ASM
23	2412-129	2	Clamp-Hose
24	93-2437	1	Plug-Serrated
25	107-9531	1	Element-Filter

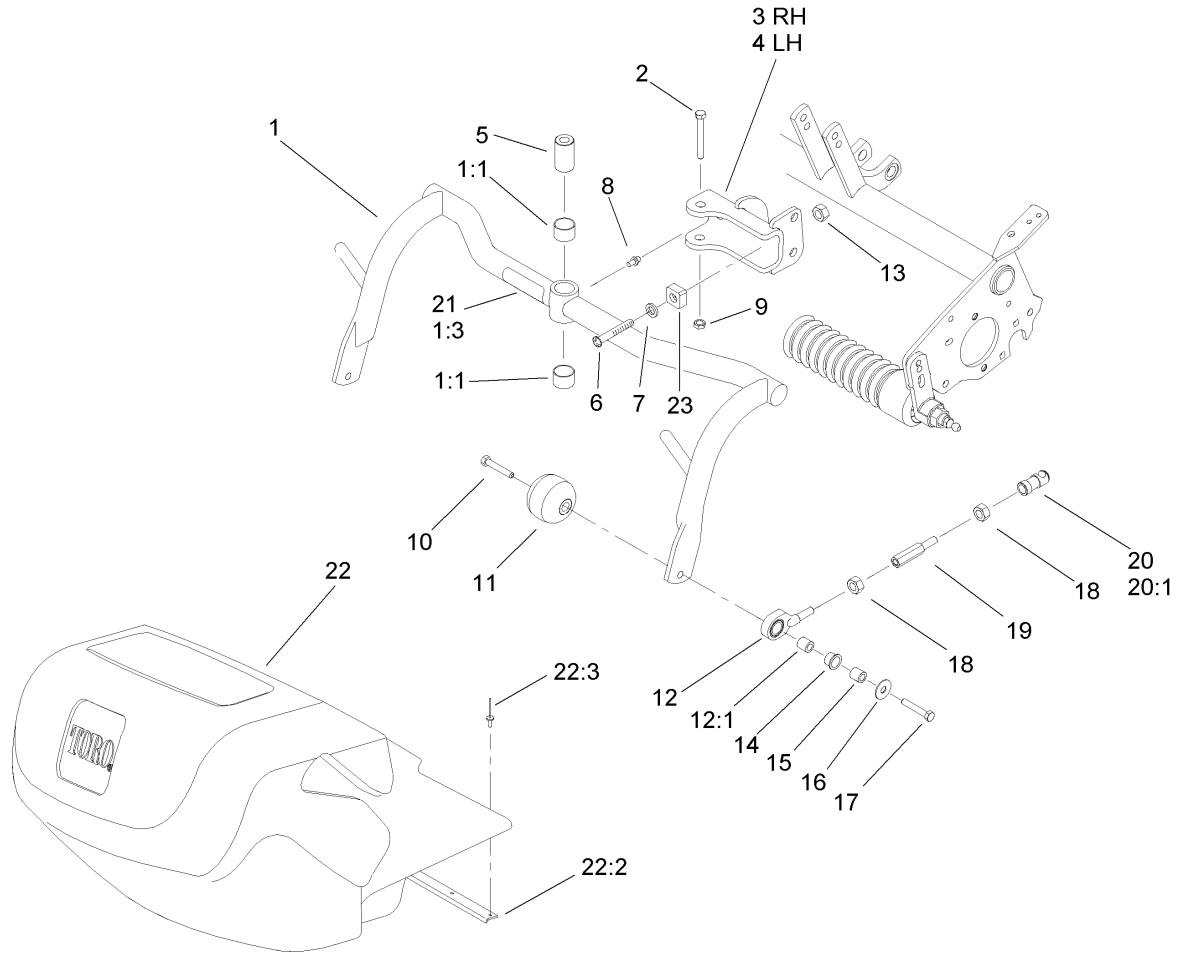

Pull Frame Assembly

Ref	Part No.	Qty.	Description
1	99-4114	3	Pull Frame ASM
1:1	98-4166	2	Bushing
1:3	104-7728	1	Decal-Danger
2	325-13	3	Screw-HH
3	99-4183-01	2	RH Clevis ASM
4	99-4182-01	1	LH Clevis ASM
5	99-4109	3	Spacer-Pivot
6	78-8710	3	Screw
7	3256-77	3	Washer-Flat
8	302-5	3	Fitting-Grease
9	3296-25	3	Nut-Lock, NI
10	99-4209	6	Shaft-Roller
11	99-4210	6	Roller-Anti Scalp
12	100-6440	6	Pull Link And Bushing ASM
12:1	95-0532	1	Rubber Bushing ASM
13	3296-12	3	Nut-Lock
14	104-7738	6	Bushing-Flange
15	75-5270	6	Spacer-Knob, Seat
16	80-6990	6	Washer-Hardened
17	323-8	6	Screw-HH
18	3220-3	12	Nut-Hex, Jam
19	99-4270	6	Extension-Arm, Pull
20	99-1460	6	Ball Joint Receiver ASM
20:1	99-1461	1	Sleeve-Joint, Ball

Ref	Part No.	Qty.	Description
21	104-7729	3	Decal-Danger (Europe)
22	106-4689	3	Grass Basket ASM
22:2	104-2607	1	Strip-Basket
22:3	3290-382	8	Rivet-Pop
23	94-1392	3	Pad-Rubber

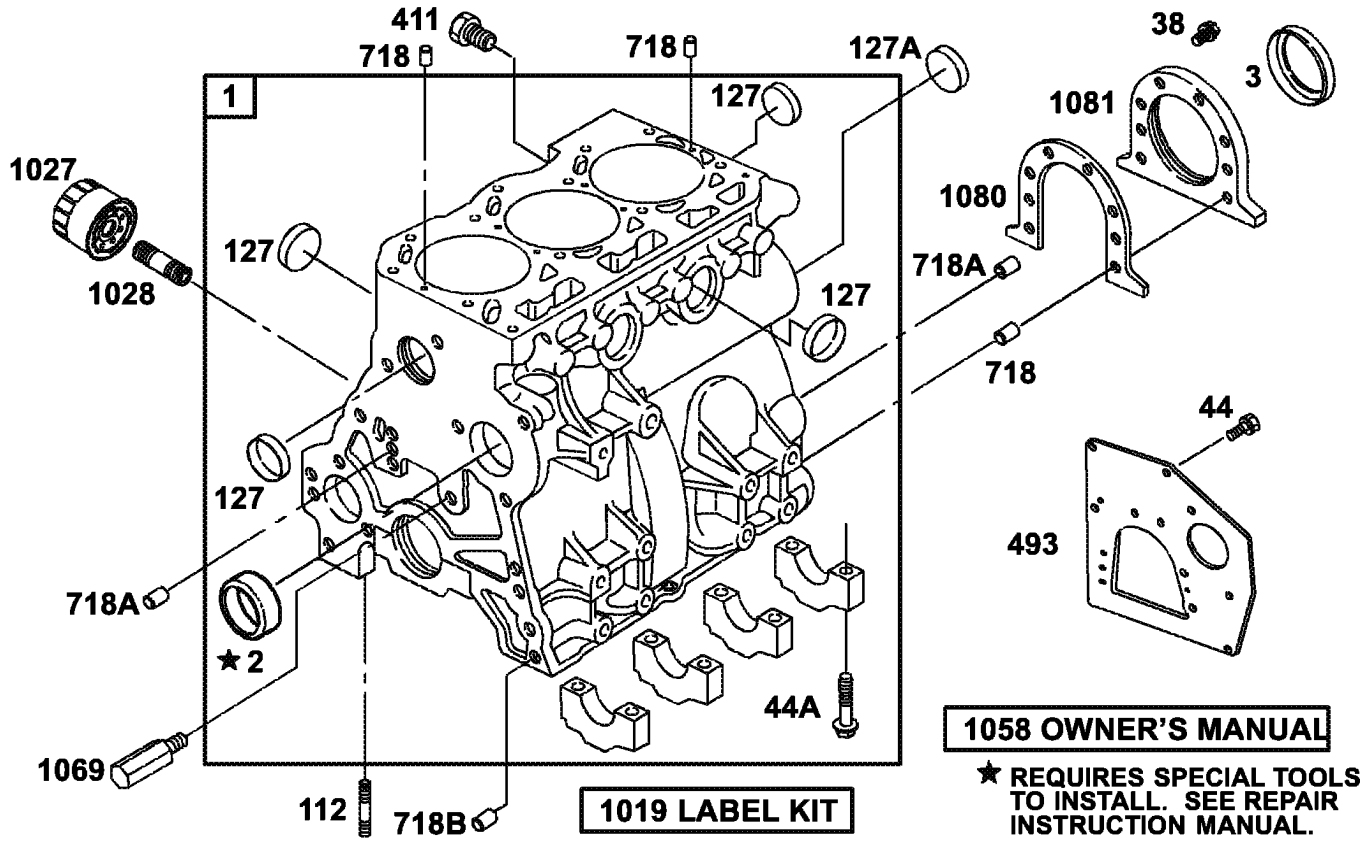

Cylinder Assembly

Ref	Part No.	Qty.	Description
1	100-6401	1	Cylinder ASM
2	99-9002	1	Bushing
3	99-9003	1	Seal-Oil
1019	99-9015	1	Label Kit
1058	99-9602	1	Manual-Owner's
1069	99-9020	1	Nozzle-Oil
1080	99-9021	1	Gasket-Retainer
1081	99-9022	1	Retainer-Seal
112	99-9007	1	Stud-Metric
1027	99-9017	1	Filter-Oil
127	99-9008	7	Plug-Welch
127A	99-9010	1	Plug-Welch
1028	99-9018	1	Adapter-Filter, Oil
38	99-9004	6	Screw-Hex
411	99-9601	1	Plug (Cylinder Block)
44	99-9005	3	Screw-Hex
44A	99-9006	8	Screw-Hex
493	100-3195	1	Bracket-Mounting
718	99-9012	4	Pin-Locating
718A	99-9013	3	Pin-Locating
718B	99-9014	2	Pin-Locating

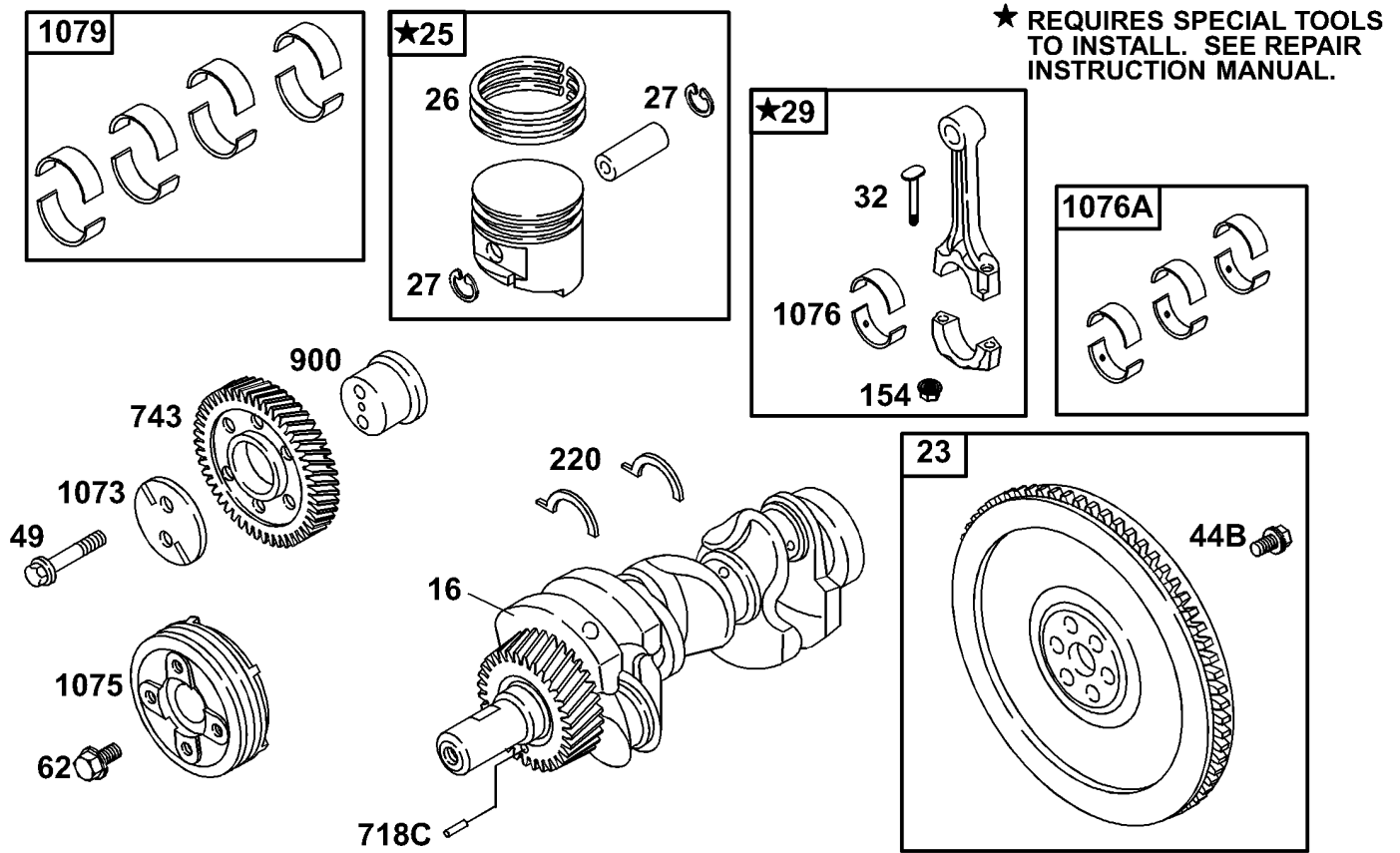

Crankshaft Assembly

Ref	Part No.	Qty.	Description
16	99-9252	1	Crankshaft
23	99-9267	1	Flywheel
25	99-9605	3	Piston ASM
25	99-9268	3	Piston ASM (.010 In Oversized)
26	99-9606	3	Ring Set
26	99-9269	3	Ring Set (.010 In Oversized)
27	99-9607	6	Lock-Pin, Piston
29	99-9608	3	Rod-Connecting
32	99-9030	6	Screw-Rod, Connecting
49	99-9032	2	Screw-Hex
62	99-9033	1	Screw-Hex
154	99-9034	6	Nut-Hex
220	99-9035	1	Washer-Thrust
220	99-9036	1	Washer-Thrust (.005 In Oversized)
44B	99-9031	6	Screw-Hex
743	99-9609	1	Gear-Drive
900	99-9039	1	Shaft-Gear
1073	99-9040	1	Plate-Gear, Idler
1075	99-9692	1	Pully-Crankshaft
1076	99-9042	1	Bearing-Rod
1079	99-9045	1	Set-Bearing, Main (Set Of 8)
1079	99-9046	1	Set-Bearing, Main (.010 Undersized)

Ref	Part No.	Qty.	Description
718C	99-9037	1	Pin-Locating
1076A	99-9043	3	Set-Bearing, Rod
1076A	99-9044	3	Set-Bearing, Rod (.010 Undersized)

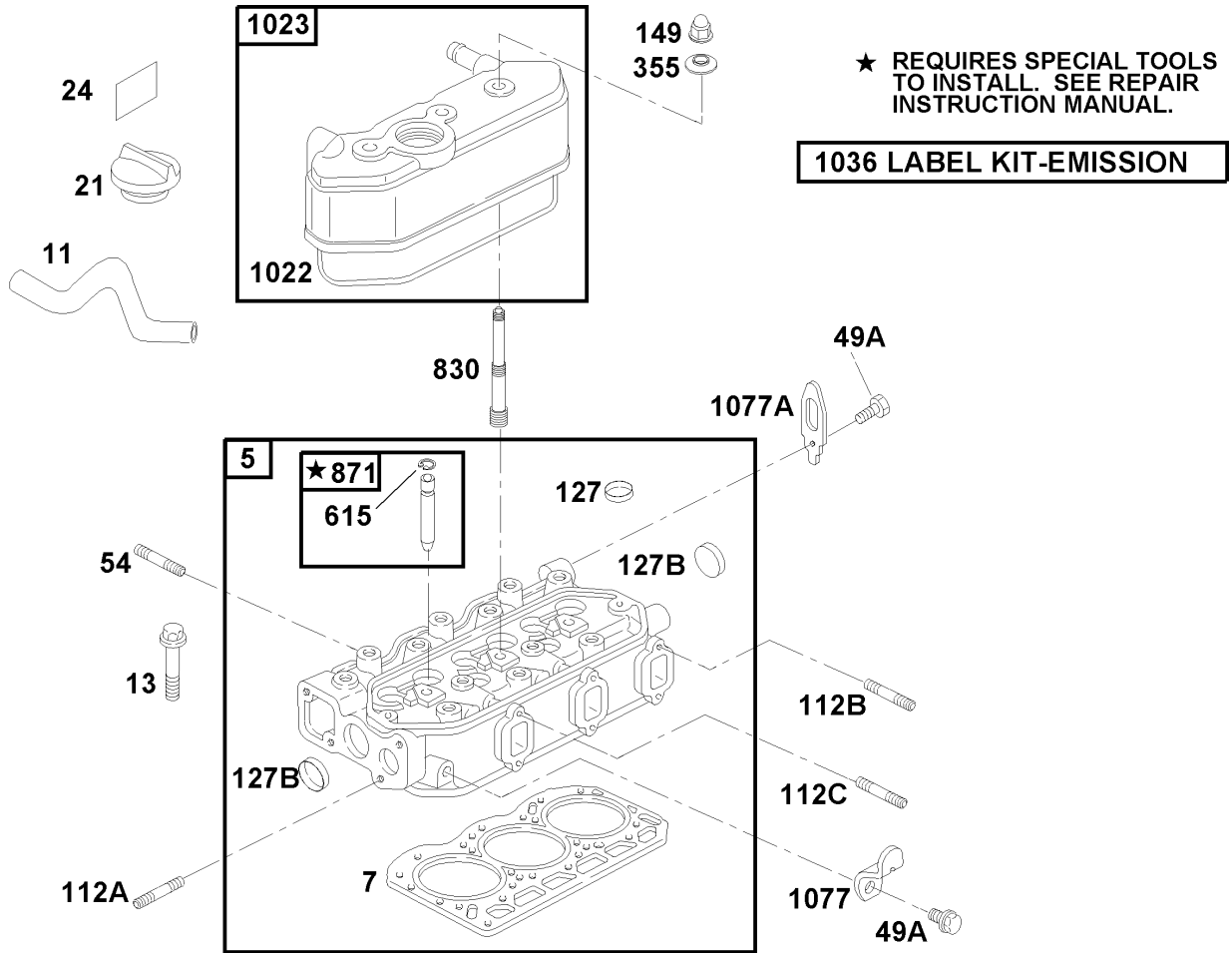

Cylinder Head Assembly

Ref	Part No.	Qty.	Description
5	99-9611	1	Head-Cylinder
7	99-9612	1	Gasket-Head, Cylinder
11	104-7743	1	Tube-Breather
13	99-9614	14	Screw-Metric
21	99-9052	1	Cap-Fill, Oil
24	105-3817	1	Label-Fill, Oil
54	99-9055	2	Stud-Metric
127	99-9008	2	Plug-Welch
149	99-9061	3	Nut-Hex, Metric
355	99-9063	3	Washer-Seal
49A	99-9054	2	Screw-Hex
615	99-9067	6	Retainer
830	99-9101	3	Stud-Arm, Rocker
871	99-9070	6	Bushing-Guide
1022	99-9073	1	Gasket-Cover, Rocker
1023	100-6402	1	Cover-Rocker
1036	99-9615	1	Emission Label Kit
1077	99-9076	1	Bracket-Lifting
112A	99-9057	2	Stud-Metric
112C	99-9059	1	Stud-Metric
112B	99-9058	5	Stud-Metric
127B	99-9060	2	Plug-Welch
1077A	99-9077	1	Bracket-Lifting

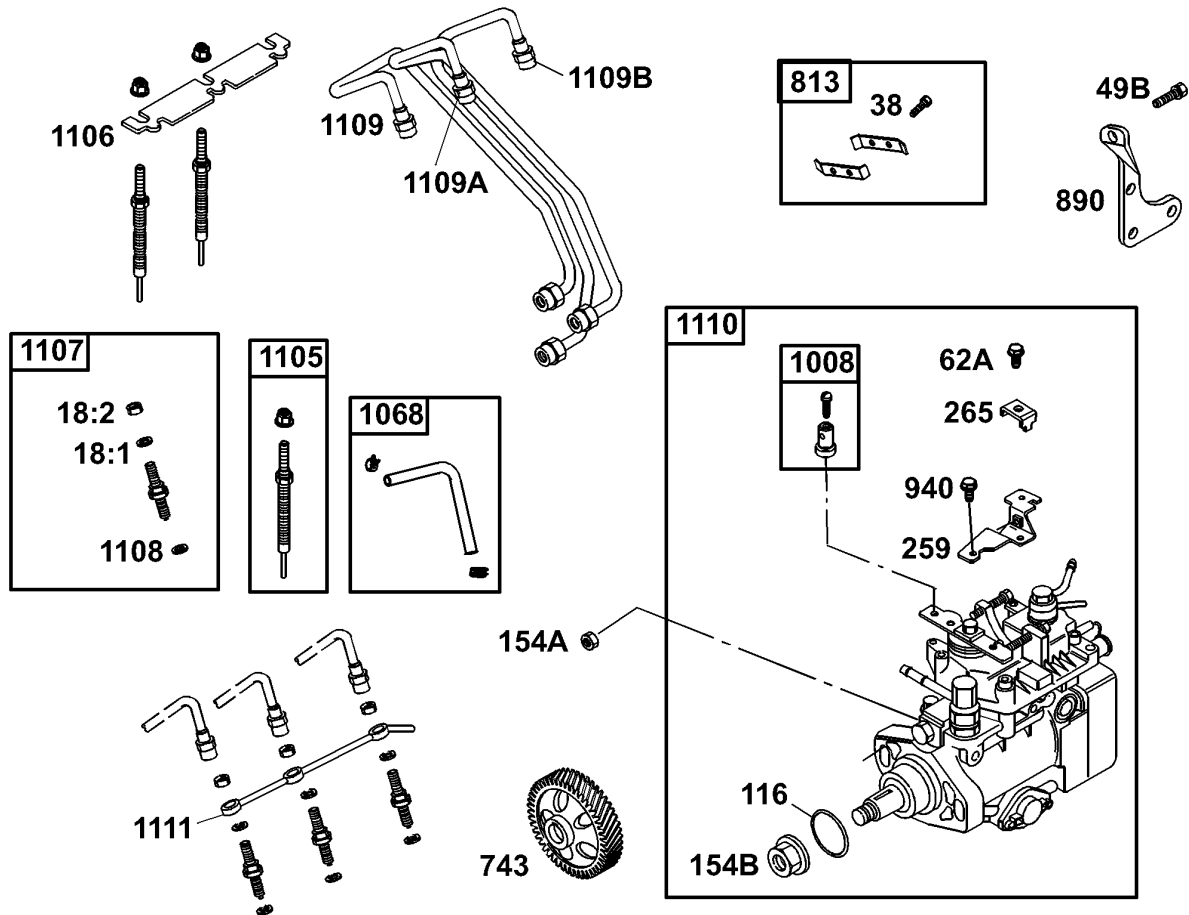

Injection Assembly

Ref	Part No.	Qty.	Description
38	99-9004	2	Screw-Hex
116	99-9618	1	O-Ring
259	99-9621	1	Bracket-Clamp, Casing
265	99-9622	1	Clamp-Casing
49B	99-9616	4	Screw-Hex
62A	100-6403	1	Screw-Metric
743	99-9624	1	Gear-Drive
813	99-9625	1	Clamp
890	99-9626	1	Bracket-Support
940	100-6410	2	Screw-Hex
1008	99-9628	1	Clamp-Swivel
1068	99-9629	1	Hose / Clamp ASM
1105	99-9630	3	Plug-Glow
1106	99-9631	1	Strap-Plug, Glow
1107	105-9789	3	Injection Nozzle
1108	99-9633	3	Seat-Injector
1109	99-9690	1	Pipe-Injector, No. 1
1110	106-6364	1	Pump-Injection
1111	99-9637	1	Pipe-Return, Fuel
154A	99-9619	2	Nut-Hex, Metric
154B	99-9620	1	Nut-Hex, Metric
1109A	99-9634	1	Pipe-Injector, No. 2
1109B	99-9635	1	Pipe-Injector, No. 3
18:1	100-5148	1	Washer

Ref	Part No.	Qty.	Description
18:2	100-5149	1	Nut-Hex

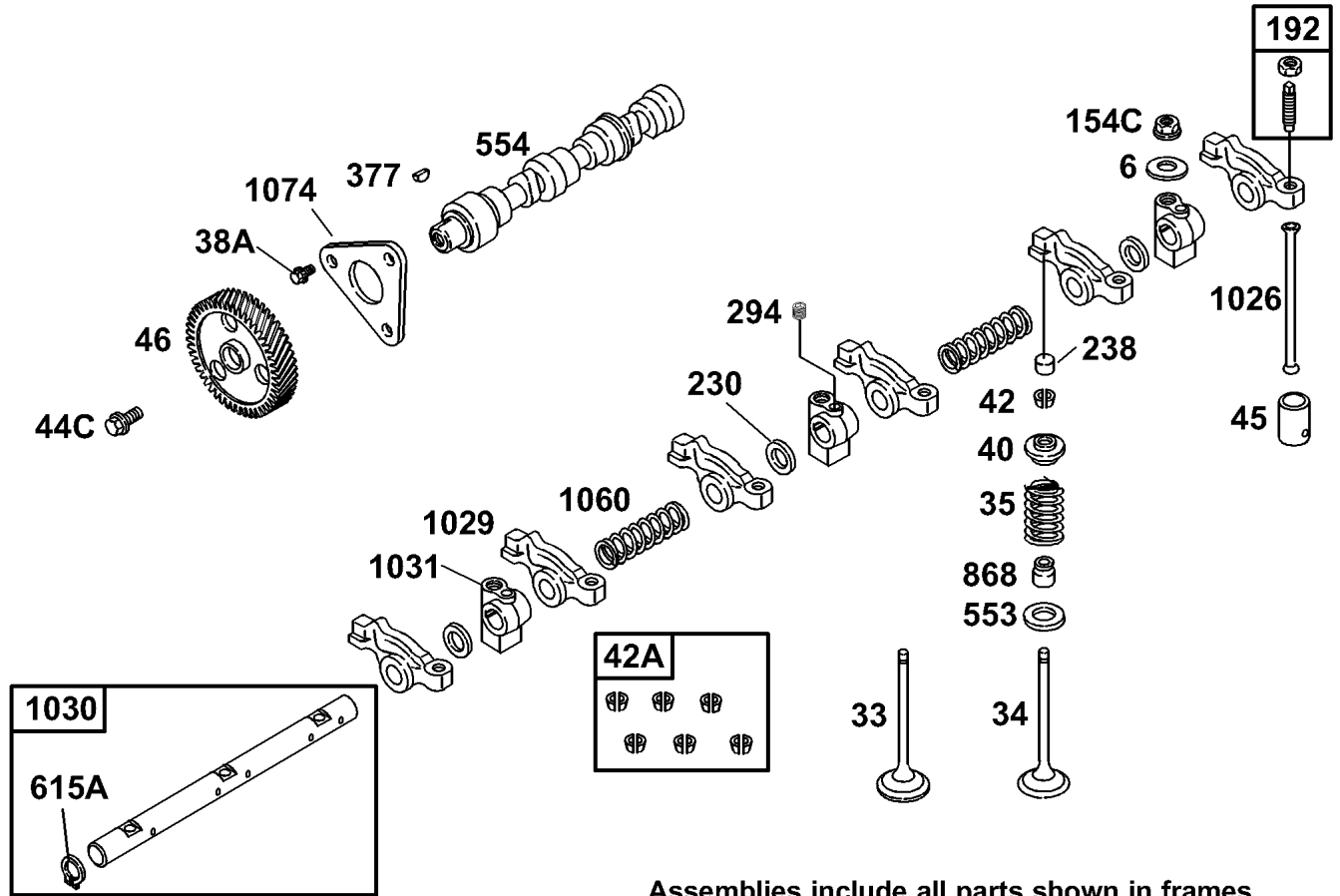

Assemblies include all parts shown in frames.

Rocker Arm Assembly

Ref	Part No.	Qty.	Description
6	99-9079	3	Washer-Flat
33	99-9638	3	Valve-Exhaust
34	99-9639	3	Valve-Intake
35	99-9640	6	Spring-Valve
40	99-9084	6	Retainer-Valve
42	99-9086	1	Keeper-Valve
45	99-9088	6	Tappet-Valve
46	99-9641	1	Gear-Cam
192	99-9092	6	Adjuster-Arm, Rocker
230	99-9093	3	Washer-Spacer
238	99-9094	6	Cap-Valve
294	99-9090	1	Screw-Metric
377	99-9642	1	Key-Timing
38A	99-9083	3	Screw-Hex
42A	99-9087	6	Keeper-Valve (Set Of 6)
44C	99-9085	1	Screw-Metric
553	99-9096	6	Seat-Spring, Valve
554	99-9097	1	Shaft-Cam
868	99-9643	6	Seal-Valve
1026	99-9103	6	Rod-Push
1029	99-9104	1	Arm-Rocker
1030	99-9106	1	Shaft-Arm, Rocker
1031	99-9107	3	Support-Arm, Rocker
1060	99-9108	2	Spring-Shaft, Rocker

Ref	Part No.	Qty.	Description
1074	99-9109	1	Retainer-Camshaft
154C	99-9091	3	Nut-Hex, Metric
615A	99-9099	2	Retainer

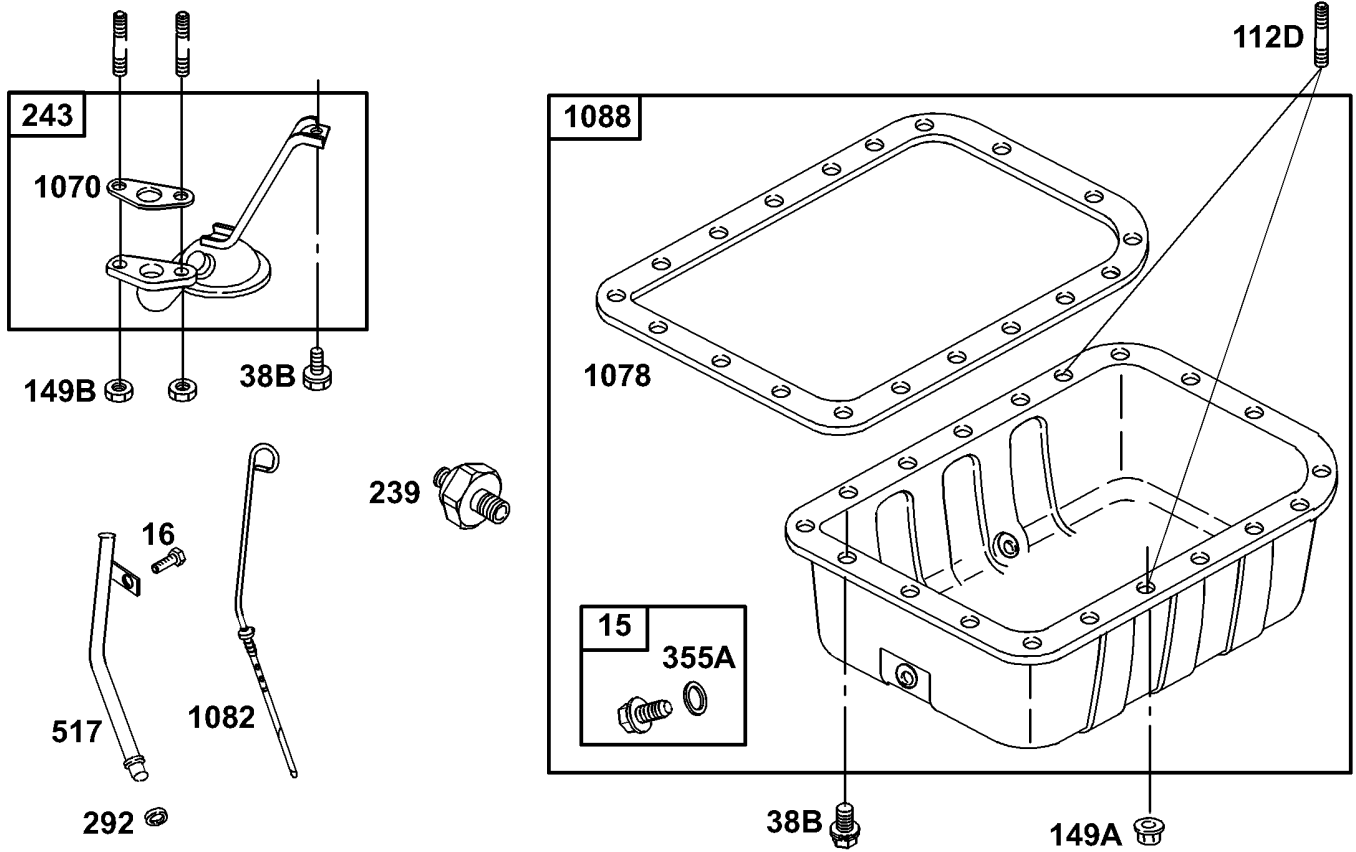

Oil Pan Assembly

Ref	Part No.	Qty.	Description
1070	99-9120	1	Gasket-Strainer, Oil
1078	99-9121	1	Gasket-Pan, Oil
1082	100-6405	1	Dipstick
1088	99-9649	1	Pan-Oil
112D	99-9112	2	Stud-Metric
149A	99-9113	2	Nut-Hex, Metric
149B	99-9114	2	Nut-Hex, Metric
15	99-9644	1	Plug-Drain, Oil
16	99-9256	1	Screw-Hex
239	99-9115	1	Switch-Pressure, Oil
243	99-9116	1	Screen-Pump, Oil
292	99-9265	1	O-Ring (Dipstick)
355A	99-9645	1	Washer-Seal
38B	99-9111	18	Screw-Hex
517	100-6406	1	Tube-Dipstick

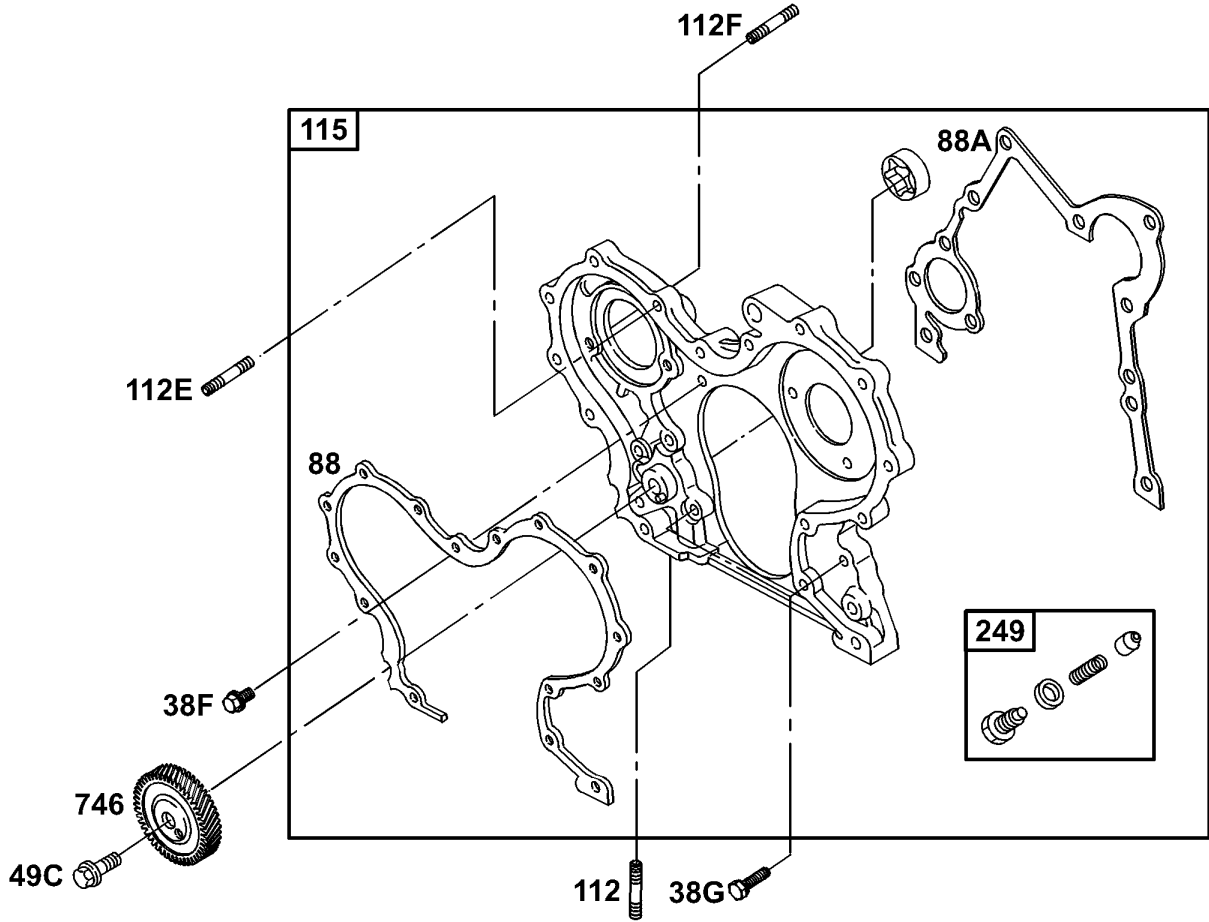

Gear Housing Assembly

Ref	Part No.	Qty.	Description	
88	99-9653	1	Gasket-Cover, Gear	
112	99-9007	1	Stud-Metric	
115	99-9655	1	Housing-Gear	
249	99-9142	1	Valve-Relief, Oil	
38F	99-9134	1	Screw-Hex	
38G	99-9133	4	Screw-Hex	
49C	99-9135	1	Screw-Hex	
746	99-9656	1	Gear-Drive	
88A	99-9136	1	Gasket-Cover, Gear	
112E	99-9137	2	Stud-Metric	
112F	99-9654	2	Stud-Metric	

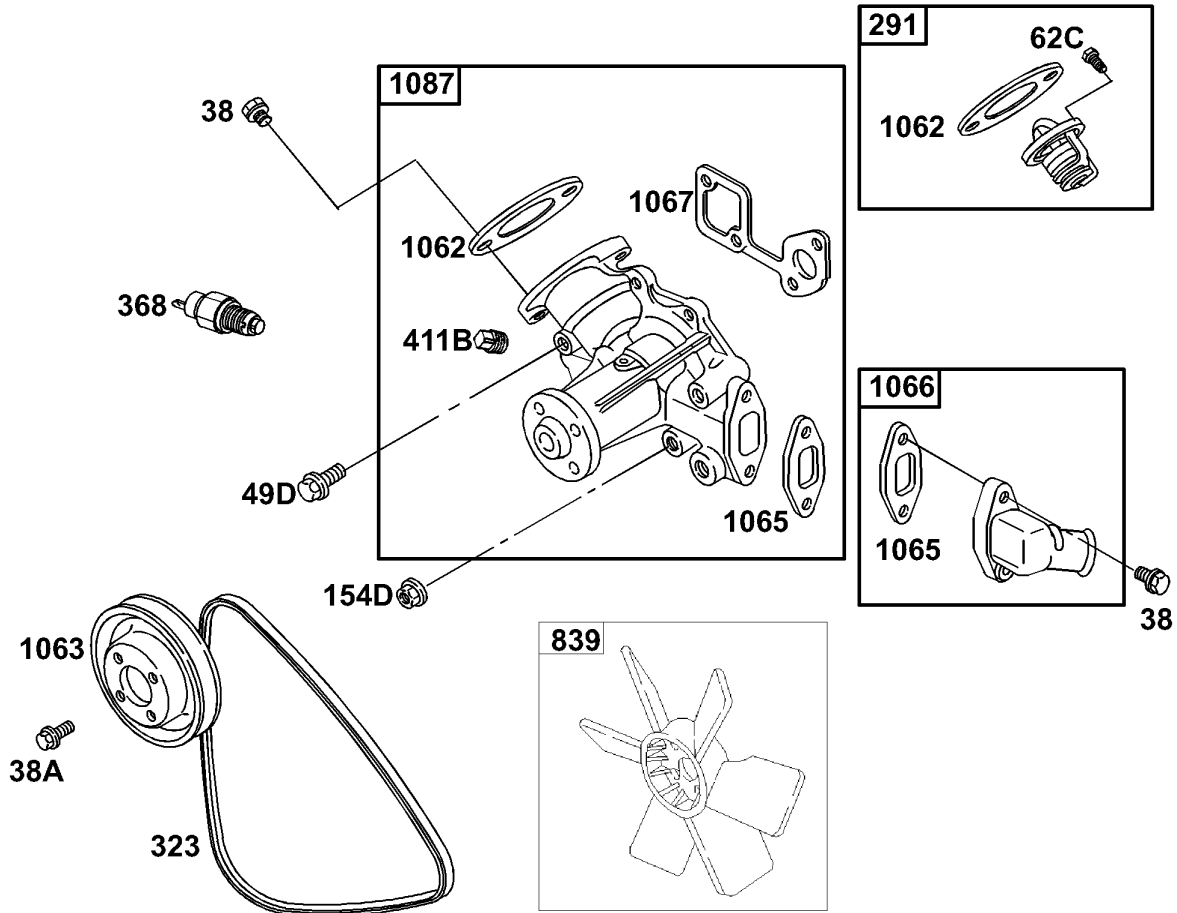

Water Pump Assembly

Ref	Part No.	Qty.	Description
1062	99-9163	1	Gasket-Outlet
1063	99-9164	1	Pulley-Pump
1065	99-9166	1	Gasket-Housing, Inlet
1066	99-9167	1	Housing-Inlet
1067	99-9168	1	Gasket-Pump, Water
1087	105-3832	1	Pump-Water
154D	99-9153	1	Nut-Hex, Metric
291	99-9155	1	Thermostat
323	99-8153	1	Belt-V
368	99-9157	1	Switch-Temperature, Water
38	99-9004	2	Screw-Hex
38A	99-9111	4	Screw-Hex
411B	99-9159	1	Plug
49D	99-9151	2	Screw-Hex
62C	99-9152	1	Screw-Metric
839	93-2090	1	Fan-Engine

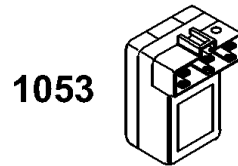
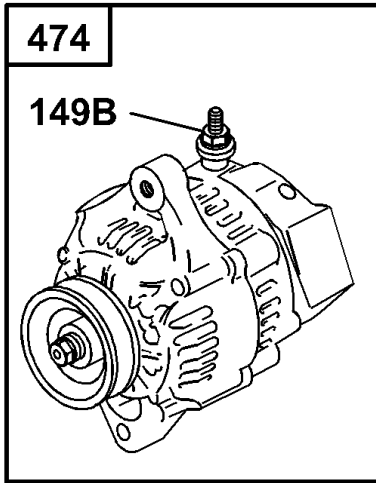
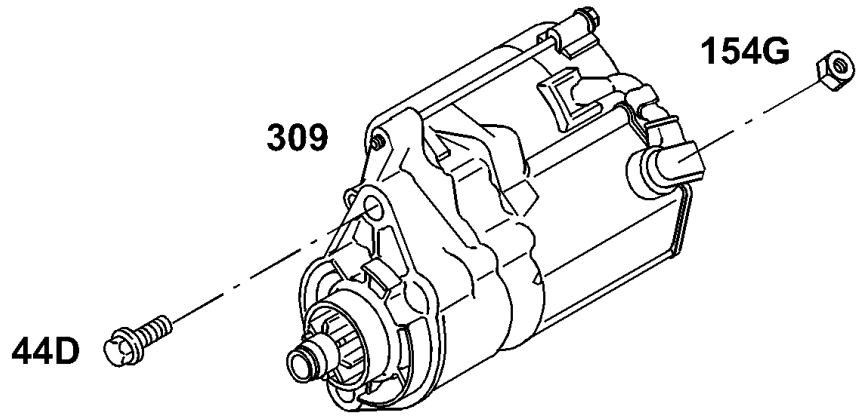

Alternator Assembly

Ref	Part No.	Qty.	Description
309	104-7716	1	Motor-Starter
44D	99-9201	2	Screw-Hex
474	99-9209	1	Alternator
1053	99-9666	1	Module
149B	99-9114	1	Nut-Hex, Metric
154G	99-9206	1	Nut-Hex, Metric

--	--	--	--

Attachments and Accessories

For 04383 - Greensmaster 3250-D

Product Name	Model/Part
Dethatching Reel ASM	04493
Spiker Kit	04494
Tri-Roller Kit	04495
Leak Detector Kit	04497
Light Kit	04551
Roll-Over Protection Kit	04552
Three Wheel Drive Kit	04553
8-Blade DPA Reel Mower	04610
11-Blade DPA Reel Mower	04611
Hose Adapter Kit	100-6430
Oil Cooler Kit	104-7701
Ground-Following Suspension Kit	104-9400
Radiator Screen Kit	105-9766
Arm Rest Kit	30707
Tie Down Kit	94-6379
Screen-Spark Arrestor	94-8157
Tire-Mate, Turf	99-4506

NOTES

NOTES

