



**Count on it.**

**Parts Catalog**

**Power Clear Snowthrower**

Model No. 38589—Serial No. 31000001 and Up

# Ordering Replacement Parts

To order replacement parts, please supply the part number, the quantity, and the description of each part desired.

## Understanding Reference Numbers

Each identified part in an illustration has a reference number. The reference number for a part also appears in the parts list, along with other information about the part.

This catalog uses two special reference number formats, one to indicate parts in a service assembly and another to indicate the quantity of a given part in an illustration.

## Service Assembly Reference Numbers

Parts in service assemblies have reference numbers in the form a:b. The a represents the reference number of the entire service assembly and the b represents a sequential number unique to each part within the service assembly.

For example, a wheel assembly might be identified by reference number 6, the tire by 6:1, the valve by 6:2, and the wheel by 6:3. When you order the assembly identified by reference number 6, you receive all parts identified by reference numbers 6:1, 6:2, and 6:3. However, you may also order any part individually. Reference numbers of this type appear in illustration and in parts lists.

## Reference Numbers Indicating Quantity

In an illustration, if a reference number indicates more than one part, the reference number has the form nX y. The n represents the quantity of the part, the X is the multiplication symbol, and the y represents the reference number.

For example, in an illustration, the reference number 2X 37 means that two of the parts identified by reference number 37 are indicated.

# List of Abbreviations

**AR:** as required  
**ASM:** assembly  
**BBC:** blade brake clutch  
**CARR:** carriage  
**CCW:** counter clock wise  
**CW:** clockwise  
**DEG:** degrees  
**ECM:** electronic control module  
**EXT:** external  
**FH:** flat head  
**GA:** gauge  
**HD:** heavy-duty  
**HF:** hex flange  
**HH:** hex head  
**HHF:** hex head flange  
**HHFTF:** hex head flange thread forming  
**HJ:** hex jam  
**HLH:** hex lag head  
**HOC:** height-of-cut

**HSBH:** hex socket button head  
**HSFH:** hex socket flat head  
**HSH:** hex socket head  
**HWH:** hex washer head  
**HWHTF:** hex washer head thread forming  
**HYD:** hydraulic  
**LH:** left hand  
**NI:** nylon insert  
**NPTF:** national pipe thread fine  
**PFH:** phillips flat head  
**PPH:** phillips pan head  
**PPHTF:** phillips pan head thread forming  
**PRH:** phillips round head  
**PTH:** phillips truss head  
**PTO:** power-take-off  
**RH:** right hand  
**ROPS:** roll-over protection system  
**RRB:** rear roller brush

**SFH:** slotted fillister head  
**SHH:** slotted hex head  
**SHWH:** slotted hex washer head  
**SPH:** slotted pan head  
**SQH:** square head  
**SRH:** slotted round head  
**STD:** standard  
**TAP:** self tapping  
**TTH:** torx truss head

# Contents

Main Frame Assembly .....	4
Rotor Drive Assembly .....	5
Rotor Assembly .....	6
Engine Assembly .....	7
Electric Start Engine Component Assembly No. 119-1942 .....	8
Shroud Assembly .....	9
Chute Control Assembly .....	10
Upper Handle Assembly .....	11
Handle Chute Control Assembly .....	12

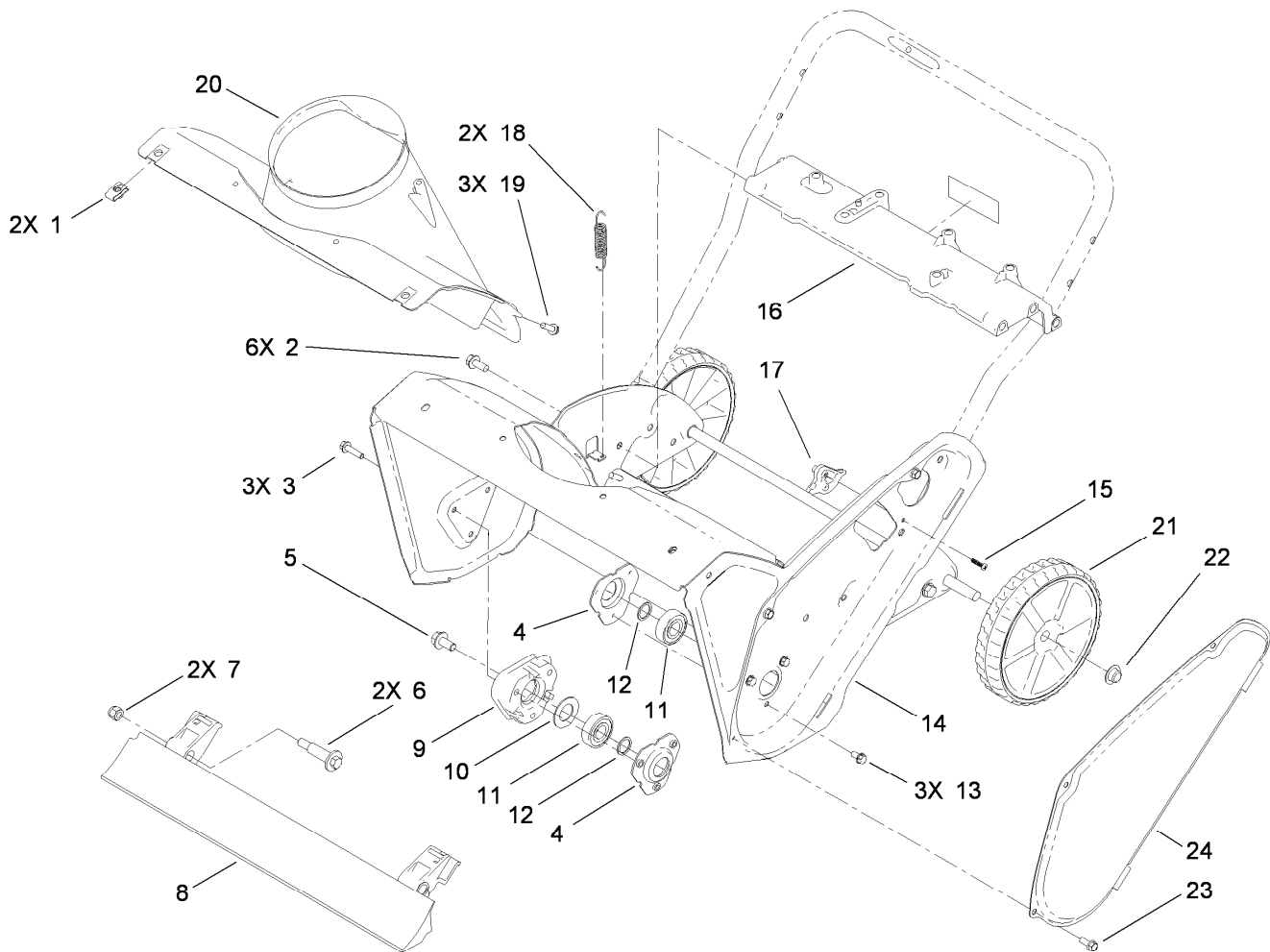

## Main Frame Assembly

Ref.	Part Number	Qty.	Description
1	107069	2	Clip
2	32144-11	6	Screw-HWHTF
3	32144-86	3	Screw-HWHTF
4	108-4943	2	Flange-Bearing
5	110-9380	1	Screw-HWH
6	56-6590	2	Bolt-Wheel
7	3296-39	2	Nut-Lock, NI
8	108-4884	1	Blade-Scraper
9	114-3781	1	Spacer-Bearing, RH
10	110-9353	1	Washer-Rubber
11	100-1048	2	Bearing-Ball
12	52-7280	2	Washer-Thrust
13	32144-4	3	Screw-HWH
14	108-4868-03	1	Housing-Auger
15	94-4496	1	Screw-PPH
16	108-4905	1	Brace-Frame
17	108-4919	1	Guide-Cable, Clutch
18	108-4906	2	Spring-Extension
19	46-8091	3	Screw-HWH
20	108-4871	1	Chute-Lower
21	117-2309	2	Wheel ASM
22	32112-14	2	Nut-Push
23	32144-85	3	Screw-HWH
24	108-4893-03	1	Cover-Belt

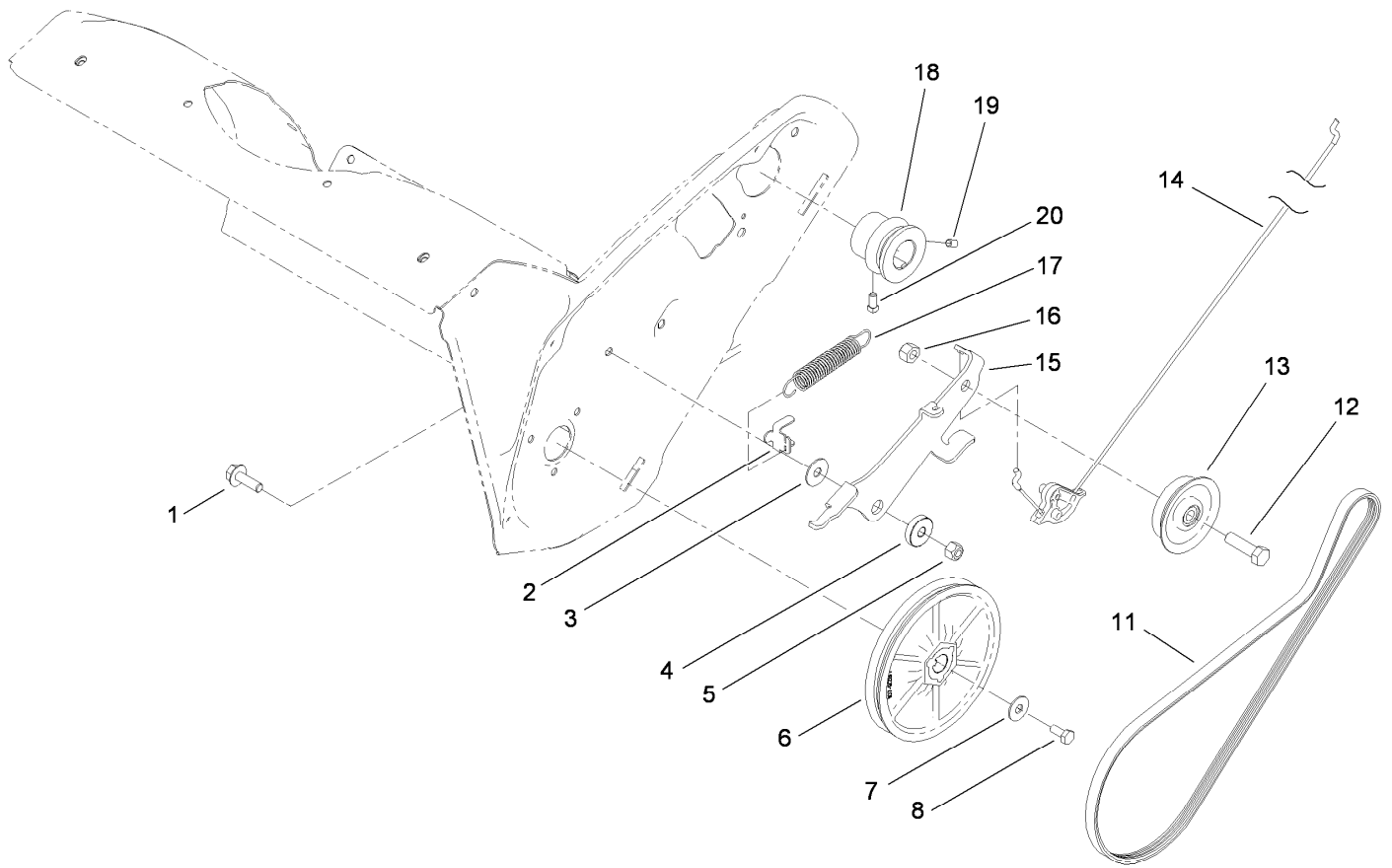

## Rotor Drive Assembly

<i>Ref.</i>	<i>Part Number</i>	<i>Qty.</i>	<i>Description</i>	<i>Ref.</i>	<i>Part Number</i>	<i>Qty.</i>	<i>Description</i>
1	3234-29	1	Screw-HHF	12	323-29	1	Screw-HH
2	108-4938	1	Clip-Spring, Brake	13	114-3785	1	Pulley-Idler
3	108-4925	1	Washer	14	115-5682	1	Cable-Clutch
4	108-4916	1	Bushing-Pivot	15	114-3782	1	Arm-Idler
5	3296-29	1	Nut-Lock, NI	16	32152-2	1	Nut-Lock, Cone
6	107-9287	1	Rotor Pulley ASM	17	114-3788	1	Spring-Extension
7	3290-456	1	Washer-Belleville	18	108-4934	1	Pulley-Engine
8	110-9381	1	Screw-HH	19	3245-32	1	Screw-HSH
11	108-4921	1	Belt-Drive	20	3241-7	1	Screw-SQH

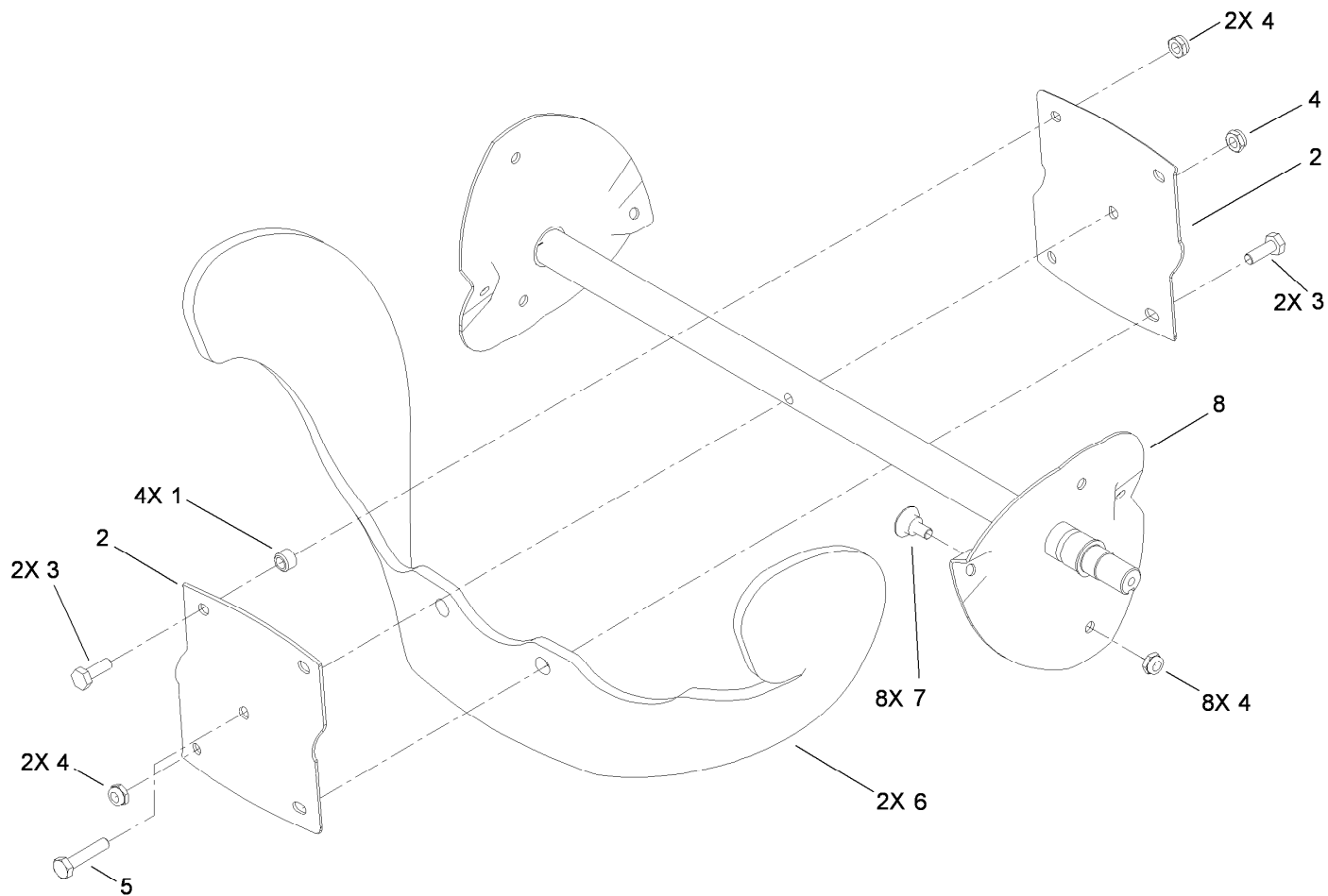

## Rotor Assembly

<i>Ref.</i>	<i>Part Number</i>	<i>Qty.</i>	<i>Description</i>
1	55-9370	4	Spacer-Blade, Rotor
2	66-6600-03	2	Half-Rotor
3	321-4	4	Screw-HH
4	3296-56	13	Nut-Lock, NI
5	321-8	1	Screw-HH
6	99-9313	2	Blade-Rotor
7	84-1971	8	Screw
8	108-4894-03	1	Rotor

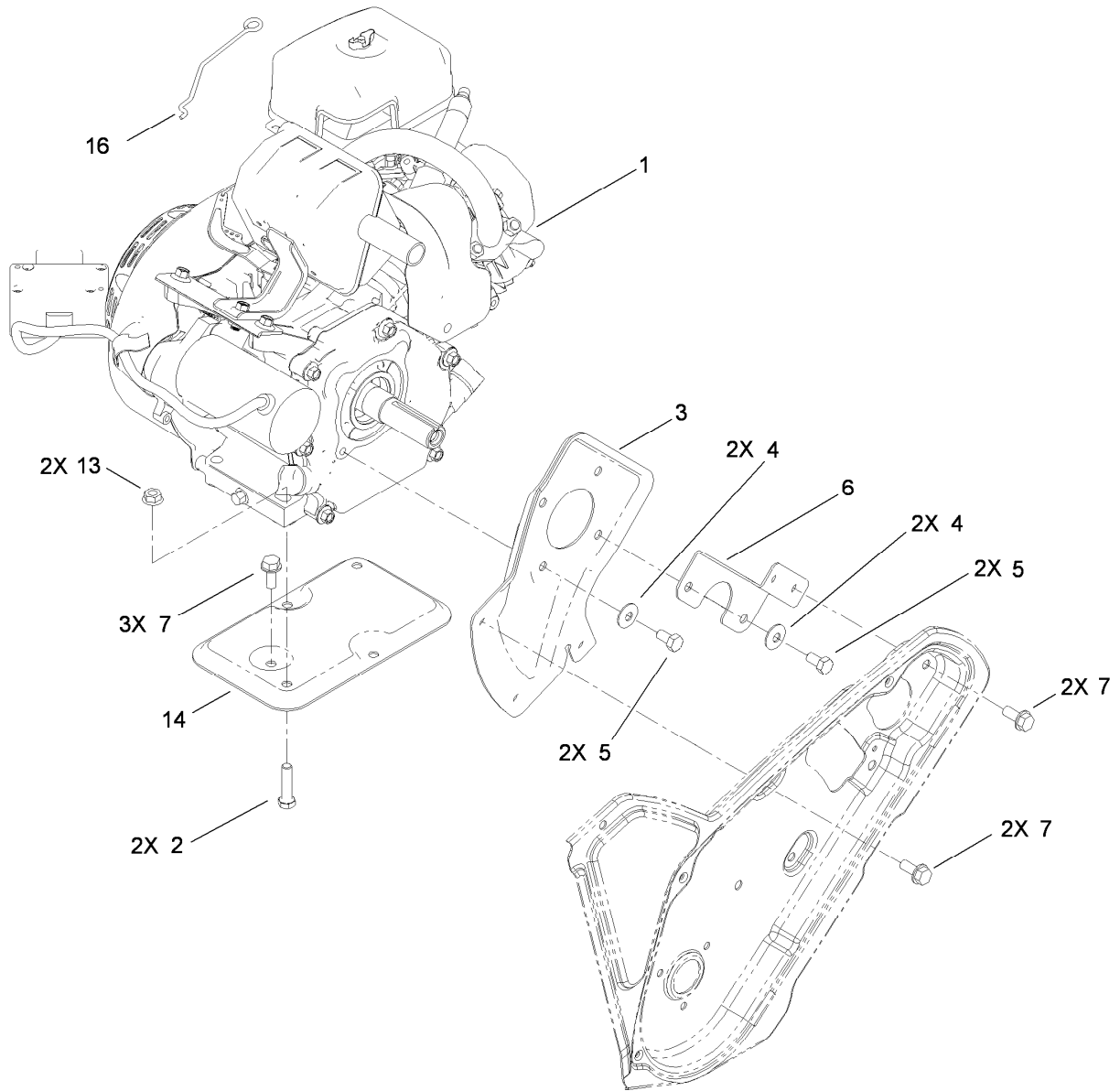

## Engine Assembly

<i>Ref.</i>	<i>Part Number</i>	<i>Qty.</i>	<i>Description</i>
1	119-1942	1	Engine-Lc168, Electric
2	322-17	2	Screw-HH
3	108-4892-03	1	Plate-Engine, PTO
4	3290-456	4	Washer-Belleville
5	33104-016	4	Screw-HHF
6	110-9354-03	1	Support-Engine, Side
7	32144-11	7	Screw-HWHTF
13	32128-20	2	Nut-HF
14	117-6037-03	1	Support-Engine
16	117-6040	1	Link-Knob, Choke

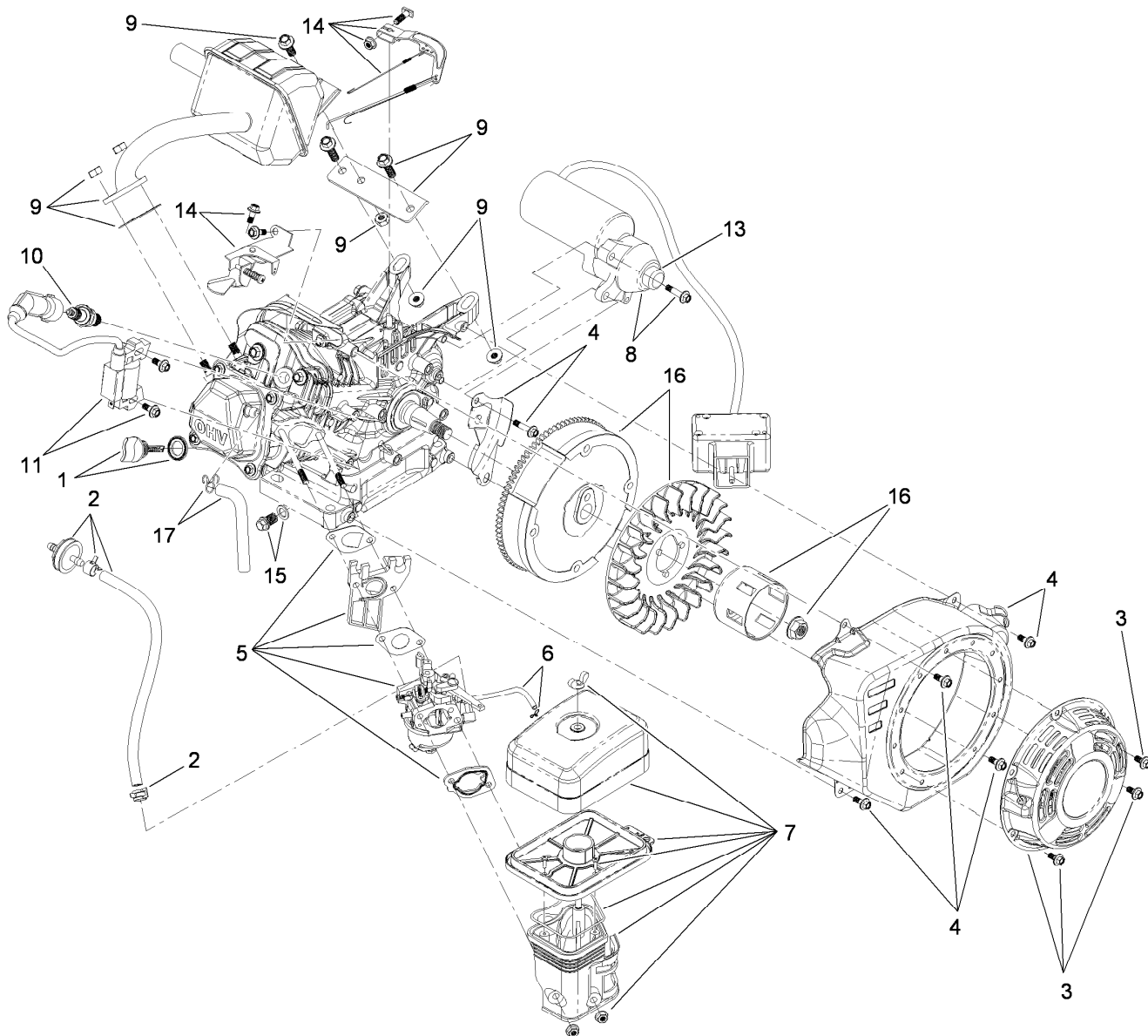

## Electric Start Engine Component Assembly No. 119-1942

Ref.	Part Number	Qty.	Description	Ref.	Part Number	Qty.	Description
1	119-1944	1	Dipstick And O-Ring Kit	9	119-1954	1	Muffler, Gasket And Hardware Kit
2	119-1953	1	Fuel Line, Filter And Clamp Kit	10	119-1901	1	Spark Plug
3	119-1945	1	Recoil And Mounting Hardware Kit	11	119-1959	1	Ignition And Mounting Hardware Kit
4	119-1946	1	Electric Blower Shroud And Hardware Kit	12	119-1955	1	Complete Engine Gasket, Seal, O-Ring Kit ●
5	119-1948	1	Carburetor, Gasket And Shield Kit	13	119-1956	1	Pinion Kit
5	119-1972	1	Carburetor Repair Kit	14	119-1957	1	Governor Arm/Link/Spring And Hardware Kit
6	119-1949	1	Primer Line And Clamp Kit	15	119-1923	1	Drain Plug Kit
7	119-1950	1	Heater Box, Manifold And Hardware Kit	16	119-1958	1	Ring Gear, Flywheel And Hardware Kit
8	119-1952	1	Electric Starter And Hardware Kit	17	119-1921	1	Breather Tube Kit

● Not illustrated

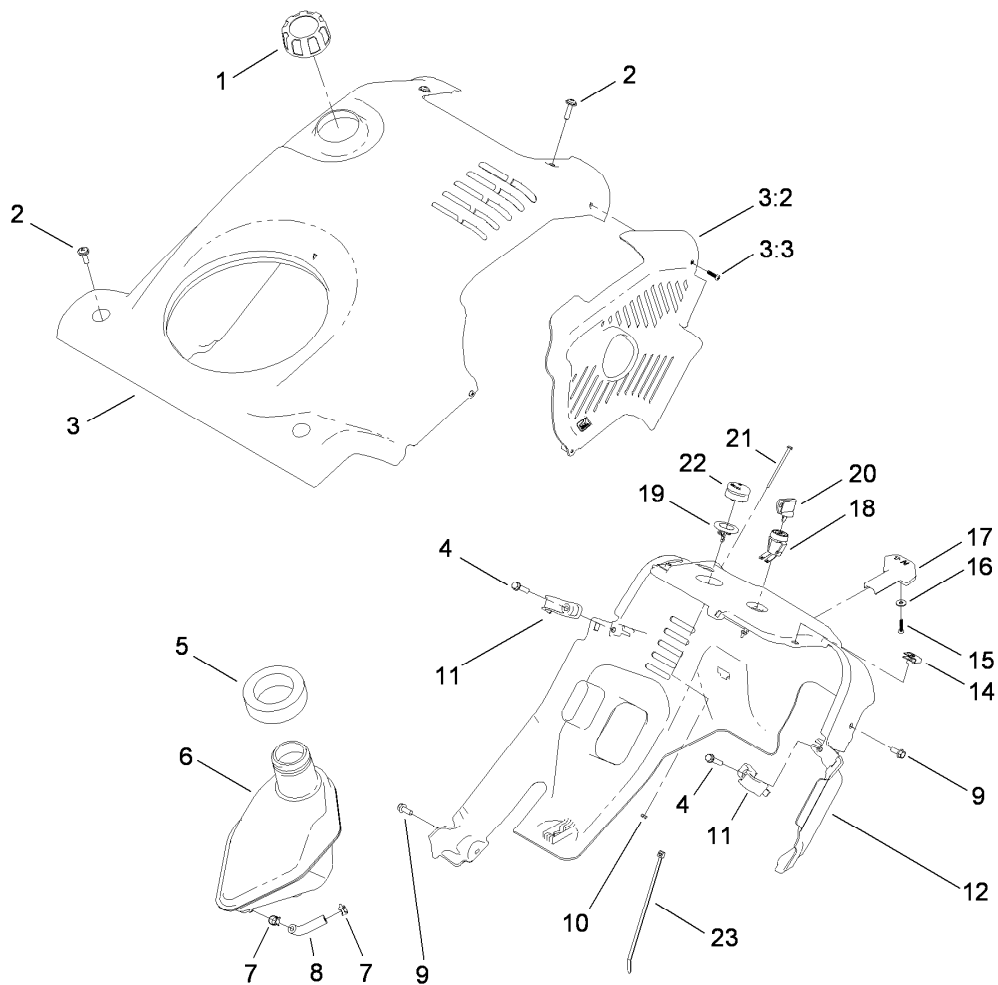

## Shroud Assembly

<i>Ref.</i>	<i>Part Number</i>	<i>Qty.</i>	<i>Description</i>
1	114-3764	1	4-Cycle Gas Cap ASM
2	110-9361	4	Screw-PPH, Sems
3	117-9129	1	Shroud ASM
3:2	117-6035	1	Baffle-Exhaust, 4-Cycle
3:3	94-4496	2	Screw-PPH
4	46-8092	2	Screw-Plastite
5	114-3773	1	Seal-Tank
6	108-4880	1	Tank-Gas
7	2412-98	2	Clamp
8	114-3765	1	Hose-Fuel
9	32144-85	1	Screw-HWH
10	3296-9	2	Nut-Lock
11	108-4947	2	Clip-Shroud
12	117-6046	1	Shroud-Lower
14	107069	2	Clip
15	94-4496	1	Screw-PPH
16	3256-49	1	Washer-Flat
17	117-9100	1	Knob-Choke
18	40-5940	1	Switch
19	44-2750	1	Body-Primer
20	63-8360	1	Key-Ignition
21	117-9106	2	Screw-HWH
22	66-7460	1	Bulb-Primer
23	614249	1	Strap-Tie

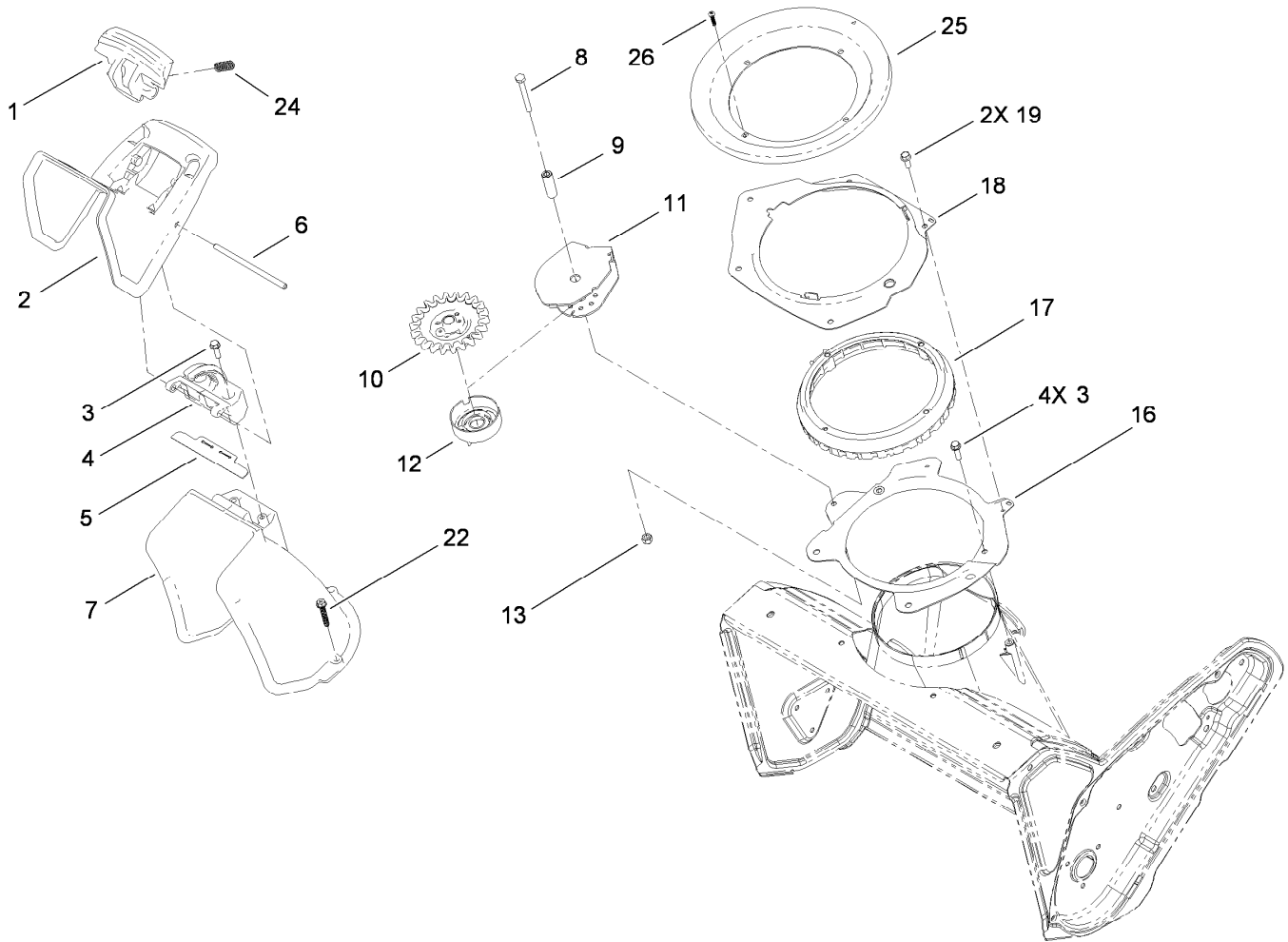

## Chute Control Assembly

<i>Ref.</i>	<i>Part Number</i>	<i>Qty.</i>	<i>Description</i>
1	108-4941	1	Trigger-Deflector
2	114-1711	1	Deflector-Chute, Ce
3	46-8091	6	Screw-HWH
4	108-4942	1	Hinge-Ratchet, Deflector
5	114-3790	1	Seal-Deflector
6	110-9368	1	Pin-Hinge, Deflector
7	108-4939	1	Chute
8	321-18	1	Screw-HH
9	108-4877	1	Spacer-Sleeve, Pinion
10	108-4875	1	Pinion-Gear
11	108-4900-03	1	Bracket-Pinion
12	114-3792	1	Retainer-Cable
13	3296-42	1	Nut-Lock, NI
16	108-4883-03	1	Ring-Support, Chute
17	108-4882	1	Ring-Chute, Gear
18	108-4874-03	1	Retainer-Ring, Chute
19	32144-85	2	Screw-HWH
22	108-4946	3	Screw-Plastite
24	110-9360	2	Spring-Compression
25	114-3772	1	Seal-Ring, Chute
26	94-4496	1	Screw-PPH

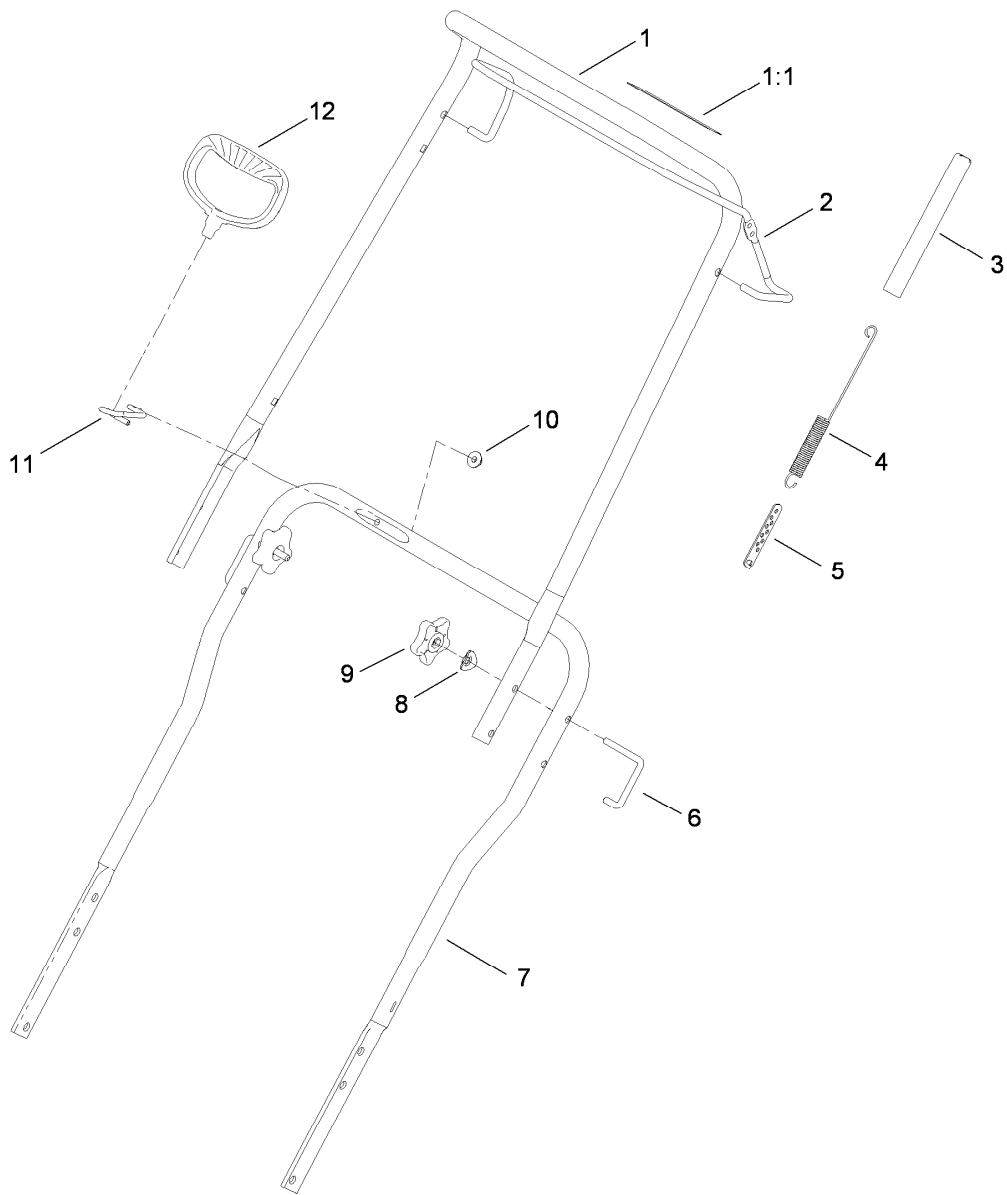

## Upper Handle Assembly

Ref.	Part Number	Qty.	Description
1	114-3768	1	Upper Handle ASM
1:1	94-2577	1	Decal-Drive, Rotor
2	114-3780-03	1	Bail-Control
3	114-3796	1	Cover-Spring
4	108-4920	1	Spring-Extension
5	71-5330	1	Adjuster-Cable, Clutch
6	108-4887	2	Lock-Handle
7	108-4944-03	1	Handle-Lower
8	107-3844	2	Washer
9	114-3779	2	Knob-Handle
10	114-3778	1	Nut-Lock, NI
11	108-4949	1	Guide-Rope
12	117-9104	1	Handle-Recoil, Blue

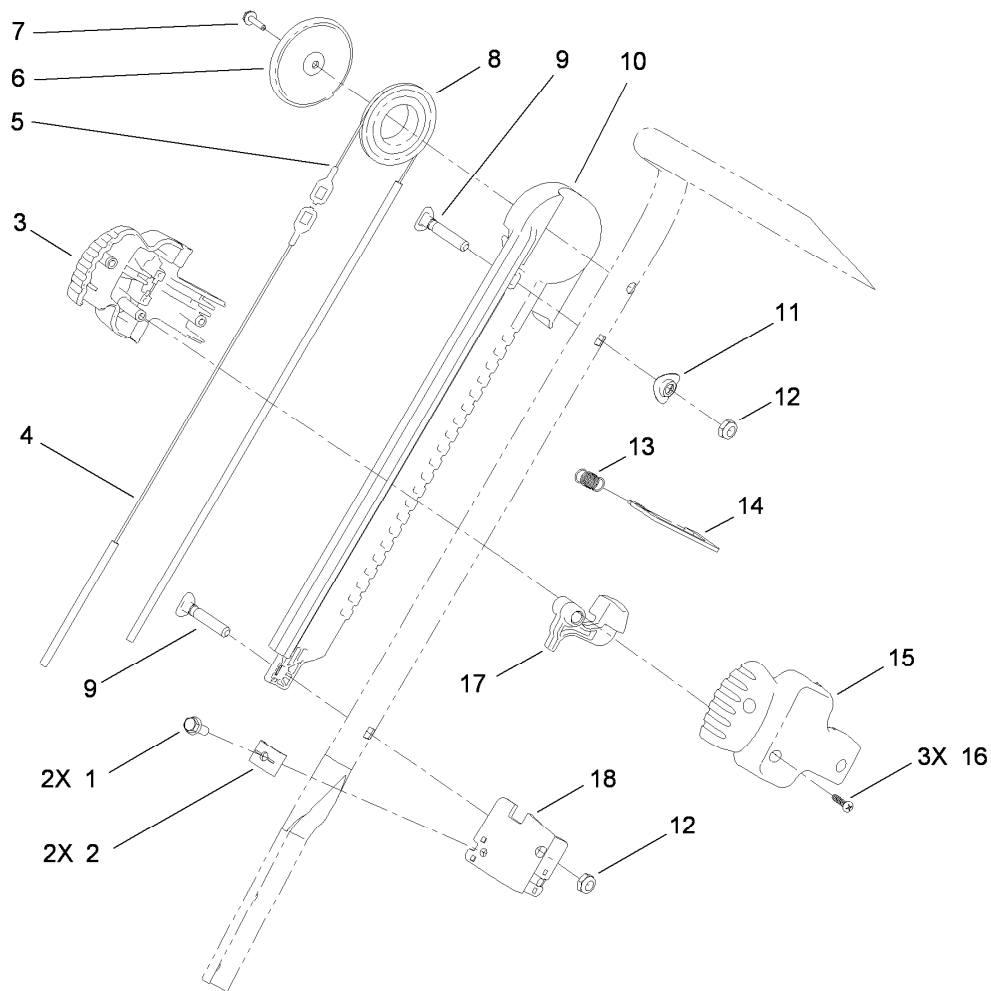

## Handle Chute Control Assembly

<i>Ref.</i>	<i>Part Number</i>	<i>Qty.</i>	<i>Description</i>
1	32144-85	2	Screw-HWH
2	106-7297	2	Clamp-Cable
3	108-4912	1	Handle-Slider, RH
4	108-4897	1	Cable-Chute, Short
5	108-4898	1	Cable-Chute, Long
6	108-4931	1	Cover-Pulley
7	98-1375	1	Screw-HWH
8	108-4907	1	Pulley-Slider
9	107-3018	2	Screw-Handle
10	108-4899	1	Track-Slider
11	107-3844	1	Washer
12	3296-47	2	Nut-Lock, NI
13	108-4914	1	Spring-Trigger
14	108-4908	1	Plate-Lock, Chute
15	108-4911	1	Handle-Slider, LH
16	94-4496	3	Screw-PPH
17	108-4913	1	Trigger
18	108-4909	1	Bracket-Cable

**Notes:**

**Notes:**

**Notes:**



**Count on it.**